

**PEDRALI S.p.A.**

sp 122 Mornico al Serio - 24050 BERGAMO - ITALY  
Export Dept. Tel: +39 035 8358840 Fax +39 035 8358888  
Ufficio Commerciale Italia Tel: +39 035 8358810 Fax +39 035 8258888

[www.pedrali.it](http://www.pedrali.it) - [info@pedrali.it](mailto:info@pedrali.it)

DESIGNSOLUTIONS 2014

**PEDRALI**<sup>®</sup>  
DYNAMIC DESIGN

DESIGNSOLUTIONS 2014

DESIGNSOLUTIONS\_1410

**PEDRALI**<sup>®</sup>

UBABILA FR FRIDA JI VOLT AY KLOG W NEN JOY K  
UMALMÖ BR SNOW JI GLISS MY KUADR JES OS I P TWEET RO-  
FABBRICO A RICK BRERA ARKI-TABL LE M DRA STEH N T P ALLURE B  
TIVOI I G CK LAJA RMORE F KON NOIKON O

DESIGN**SOLUTIONS** 2014

## Sedie - Chairs

Allure	p. 86
Ara	p. 16
Babila	p. 06
Blitz	p. 18
Brera	p. 128
Day Dream	p. 136
Dress	p. 90
Enjoy	p. 34
Ester	p. 80
Frida	p. 68
Gliss	p. 110
Gossip	p. 138
Host	p. 148
Island	p. 146
Jil	p. 88
Joi	p. 26
Koi-Booki	p. 54
Kuadra	p. 102 - 108
Kuadra XL	p. 100 - 104
Laja	p. 48
Log	p. 78
Malmö	p. 62
Mies	p. 144
Mood	p. 84
Mya	p. 22
Noa	p. 40
Pasha	p. 142
Queen	p. 140
Sign	p. 74
Snow	p. 28
Snow Junior	p. 30
Tivoli	p. 66
Tweet	p. 36
Twig	p. 94
Volt	p. 10
Young	p. 92
Zen	p. 96
Zippo	p. 150

## Sgabelli - Stools

Arod	p. 124
Babila	p. 08
Brera	p. 128
Cube	p. 130
Gliss	p. 120
Happy	p. 132
Kuadra	p. 125
Rubik	p. 122
Woody	p. 126
Malmö	p. 63
Volt	p. 13

## Tavoli - Tables

Aero	p. 85
Arki-Table	p. 52 - 56
Exteso	p. 70
Fabbrico	p. 106
Ikon	p. 04
Kuadro	p. 134
Logico	p. 14
Magic	p. 82
Matrix	p. 32
Matrix Desk	p. 44
Matrix Outdoor	p. 25
Malmö	p. 60
More	p. 20
Togo	p. 46
Surface	p. 76

## Complementi - Complements

Brick	p. 162
Code	p. 158
Flag	p. 160
Kado	p. 164
Malmö Low tables	p. 64
Parenthesis	p. 154
Set Pocket White	p. 156
Side Table White	p. 157
Wow	p. 152

## Illuminazione - Lighting

Colette	p. 166
Happy Apple	p. 168
L001	p. 72
L002	p. 42
L004	p. 98



Design Pio e Tito Toso

Art. 863V - 865 - 866 - 869

Ikon parla il linguaggio dell'architettura con la sua massima semplicità e grande pulizia formale che pare uscire dai meandri del tempo. Dining table adatto sia per indoor che per outdoor con basamento in polipropilene stampato ad iniezione abbinabile a ripiani in stratificato o vetro.  
Ikon con base Ø550 mm si abbina a ripiani in laminato o mdf dalle dimensioni generose. Basamento in polietilene rotazionale, da zavorrare.

With its timeless and clean shape, Ikon talks the architecture language. Dining table suitable for indoor and outdoor use. Injected polypropylene table base which can be combined with solid laminate or glass tops.

Ikon with Ø550 mm base can be equipped with laminate or mdf tops in larger sizes. Rotomoulded polyethylene base, to be filled.

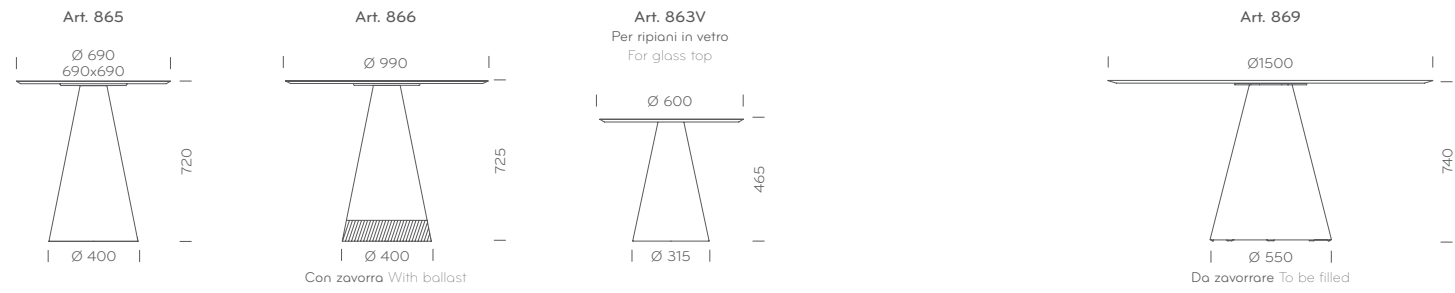

finiture basamento:  
table base finishes:

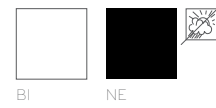

colori ripiano stratificato:  
solid laminate top colours:



colori ripiano vetro:  
glass top colours:

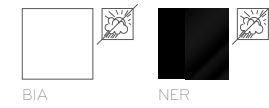

colori ripiano laminato:  
laminated top colours:

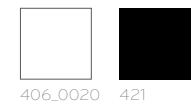

colore ripiano MDF:  
MDF top colour:

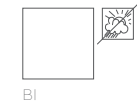

863V



# 06 Babila Tecnopolimero

Design Odo Fioravanti

## Art. 2730 - 2740 - 2750

La scocca della sedia Babila in tecnopolimero richiama il disegno della versione in legno ma sfrutta l'elasticità e la tridimensionalità del materiale plastico per offrire il massimo comfort in una veste più smart. Una delicata modanatura caratterizza la parte posteriore dello schienale. Proposta con telaio in metallo, impilabile, è disponibile anche nella versione che abbina il materiale plastico della scocca alle gambe in legno.

The technopolymer shell of Babila chair recalls the wooden version but takes full advantage of elasticity and three-dimensionality of the plastic material, in order to offer the greatest comfort in a new smarter look. A delicate moulding characterizes the back. Beside the stackable metal frame, it is available with an interesting combination of technopolymer and ash wood legs.

## colori scocca / shell colours:



BI  
SA  
GR

## finiture telaio / frame finishes:



CR  
Per art. 2730, 2740  
For item 2730, 2740

BI  
Per art. 2730, 2740  
For item 2730, 2740

NE  
Per art. 2730, 2740  
For item 2730, 2740

FR  
Per art. 2750  
For item 2750

AN  
Per art. 2750  
For item 2750

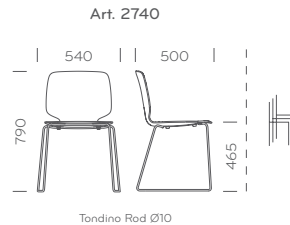
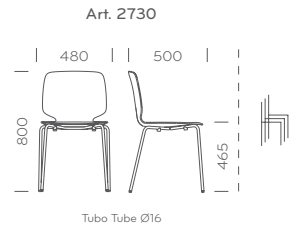

2750



2740



2730

Design Odo Fioravanti

## Art. 2700 - 2710 - 2720 - 2702

Babila è una sedia che si muove con grande agilità tra tradizione e innovazione. La scocca è realizzata in multistrato a spessore variabile e le gambe sono in massello di frassino. Disponibile nella versione con telaio a 4 gambe in tubo d'acciaio Ø16 mm oppure telaio a slitta in tondino Ø10 mm.

Lo sgabello ha gambe affusolate che si innestano nel sedile in multistrato senza l'aggiunta di parti di supporto. Un elemento in pressofusione di alluminio garantisce l'appoggio per i piedi, incorniciando il legno e donandogli robustezza.

Babila is a chair able to move along tradition and innovation with great agility. Plywood shell in variable thickness and solid ash legs. Four legs frame in steel tube Ø16 mm or sled frame in steel rod Ø10 mm available.

Ash wood barstool with an extreme lightweight look where the die-casted aluminium footrest is perfectly jointed to the legs.

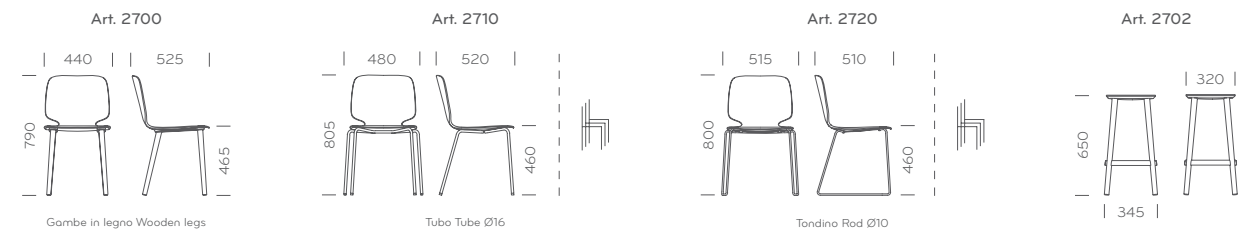

finiture scocca / shell finishes:



FR AN GC

finiture telaio / frame finishes:



CR Per art. 2710, 2720 For item 2710, 2720

ST Per art. 2702 For item 2702

BI Per art. 2710, 2720, 2702 For item 2710, 2720, 2702

NE Per art. 2710, 2720, 2702 For item 2710, 2720, 2702

FR Per art. 2700, 2702 For item 2700, 2702

AN Per art. 2700, 2702 For item 2700, 2702

GC Per art. 2700, 2702 For item 2700, 2702



2700



2702



# Volt



Design Claudio Dondoli and Marco Poggi



reddot award 2014  
winner

### Art. 670 - 675

Il tratto sottile e lineare, le gradevoli proporzioni e i colori freschi rendono Volt una seduta che si distingue per la cura dei dettagli. Volt è realizzato in polipropilene rinforzato con fibre di vetro e stampato ad iniezione con gas air moulding. Colori: bianco, nero, rosso, grigio antracite, beige, giallo, blu.  
The thin and linear design, the graceful proportions and fresh colours make Volt a sitting that stands out for its attention to details. Volt is made of injection gas air moulding polypropylene reinforced by fibers glass. Colours: white, black, red, anthracite gray, beige, yellow, blue.

### colori / colours:

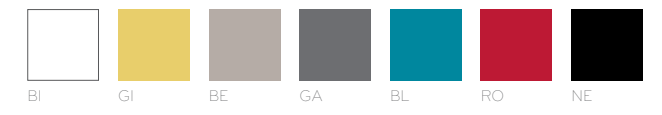

Art. 670

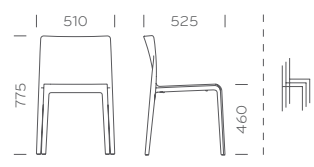

670



# Volt



Design Claudio Dondoli and Marco Poggi



reddot award 2014  
winner

## Art. 675 - 678

Lo sgabello Volt, dai volumi puri e linee definite, mantiene invariata la cura dei dettagli e la tecnologia produttiva che identificano l'omonima collezione. Le dimensioni contenute, abbinata a forme ergonomiche, assicurano funzionalità e comfort. Il poggiatesta che continua su tre lati avvolge le gambe come una fascia e aumenta la resistenza dello sgabello, garantendone l'impilabilità. Realizzato in polipropilene rinforzato con fibre di vetro e stampato ad iniezione con gas air moulding è disponibile nella stessa palette di colori della seduta.

Volt barstool, with its pure volume and its well defined lines is the result of excellent selection of the best technologies and researches in plastic materials. The compact size and ergonomic shape ensure functionality and comfort. The footrest on three sides, like a bend, grants the stackability. Made of polypropylene, injected with gas air moulding and reinforced by glass fibers, the Volt barstool is available in the same range of colours of the chair.

colori / colours:

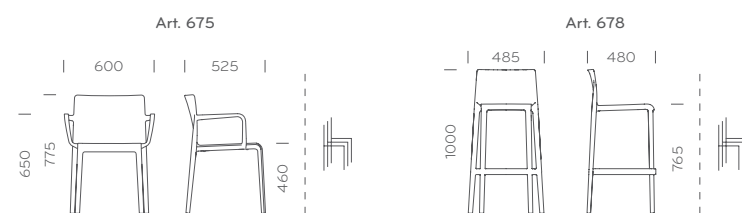

675



678





# Logico

Design Pedrali R&D

**Art. TL**

Tavolo Logico con struttura in acciaio inox satinato, verniciato bianco o nero. Ripiano in stratificato bianco o nero oppure in vetro temperato acidato. Le gambe a sezione rettangolare 60x20 mm sono orientate con angolo a 45°.

Logico table, brushed stainless steel frame, white or black powder coated frame. Frosted glass, white or black solid compact top. 60x20 mm steel tube legs are oriented with a 45° angle.

Ripiano in vetro / Glass top

Art. TL\_80X80



Art. TL\_140X80

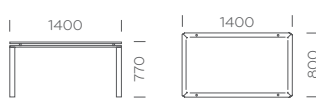

Art. TL\_90X90

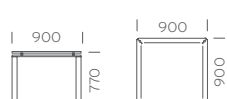

Art. TL\_180X90

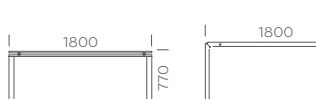

Ripiano in stratificato / Solid laminate top

Art. TL\_79X79



Art. TL\_139X79



Art. TL\_89X89

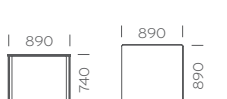

Art. TL\_179X89



finitura struttura:  
frame finish:



AC

colore ripiano vetro:  
glass top colour:

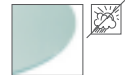

SAT

finitura struttura:  
frame finish:



BIE

colore ripiano stratificato:  
solid laminate top colour:



CFC\_BI

finitura struttura:  
frame finish:



NERO

colore ripiano stratificato:  
solid laminate top colour:



COM



TL\_179X89



# Ara



Design Jorge Pensi Design Studio



reddot design award  
winner 2013

### Art. 310 - 315 - 310.3

Ara è in polipropilene caricato con fibra di vetro, adatta sia per indoor che outdoor. La struttura dello schienale forma nella parte alta una grande maniglia che ne facilita il sollevamento e lo spostamento e le conferisce un distinto carattere. Grazie alla forma affusolata delle gambe appare leggera ed elegante, pur essendo robusta e indeformabile. Sedia e poltrona Ara sono impilabili.  
Ara is made of moulded polypropylene reinforced with fibreglass, stackable and suitable for both indoors and outdoors. The upper part of back structure forms a big handle for an easy lifting and moving, giving it a distinct character. Thanks to the tapered shape of the legs it's light and elegant, although resistant and non-deformable. Ara chair and armchair are stackable.

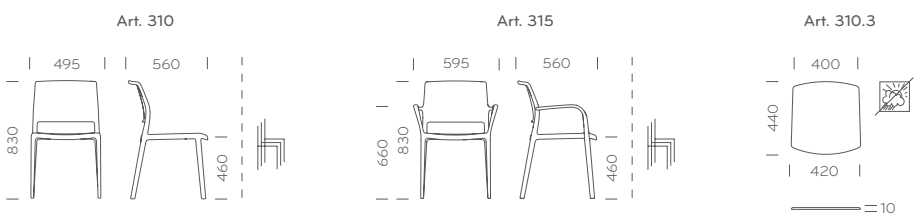

colori / colours:



Design Claudio Dondoli and Marco Poggi

## Art. 640 - 640.3

Sedia impilabile in policarbonato in vari colori, sia full colour che trasparenti. La seduta è foto-incisa e può ricevere un'imbottitura leggermente incassata e rivestita in vari tessuti. La sua forma rassicurante e la sua struttura essenziale la rendono facile da inserire in qualsiasi ambiente dove non passerò inosservata. Polycarbonate stackable chair with a strong personality in various colours and even transparent. The seat has a slight rough finish and can have a recessed padding, covered with various fabrics. Its reassuring shape and the essential structure make it easy to fit into any environment, where it will not go unnoticed.

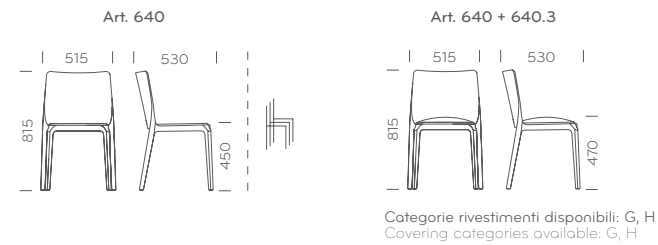

colori / colours:



## Art. 641

Blitz versione interamente rivestita in pelle o ecopelle con cuciture in tinta. Blitz soft version is entirely covered with mid-grain or simil leather, matching stitches.

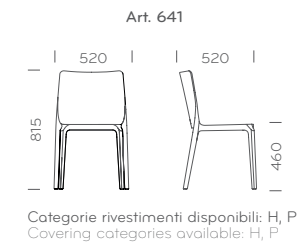

640



640 + 640.3



641

# 20 More

Design Pedrali R&D

## Art. TMO

Il tavolo allungabile More inaugura una nuova dimensione nella versatilità arredando lo spazio domestico con stile e qualità. Disponibile in 3 diverse misure, ha il telaio in acciaio sagomato con le guide scorrevoli in alluminio e il ripiano in nobilitato.  
More table is the expression of a new dimension of versatility by decorating the living space with style and quality. More table is available in three different dimensions. Shaped structural steel legs, aluminium sliding rails, melamine top.

finitura struttura:  
frame finish:  
  
Bl

colore ripiano:  
top colour:  
  
Bl

Art. TMO\_110X75

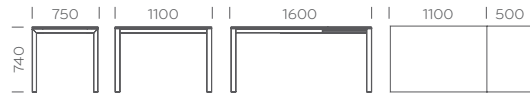

Art. TMO\_140X85



Art. TMO\_180X85





Design Claudio Dondoli and Marco Poggi

#### Art. 700

Leggera e impilabile, la sedia Mya ha seduta e schienale in polipropilene e telaio in un unico pezzo in pressofusione di alluminio con gambe offusolate. Disponibile nei colori nero, bianco, rosso, sabbia e grigio antracite. Gambe verniciate in tinta con la scocca per utilizzo outdoor oppure in alluminio lucidato o satinato per utilizzo indoor.

Lightweight and stackable, Mya chair has polypropylene seat and back and die-casted aluminium frame with tapered legs. Colours available: black, white, red, beige and anthracite gray. Powder coated aluminium legs for outdoor use in the same colour of seat and back or polished and brushed finish for indoor use.

Art. 700

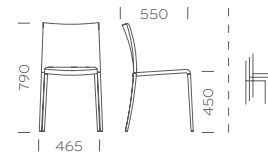

Art. 705/2

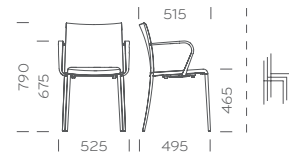

#### colori scocca / shell colours:



#### finiture telaio / frame finishes:



705/2



Art. 701 - 706/2

Mya Tecnica è la versione con seduta in polipropilene e schienale in textilene, nelle varianti sedia e poltrona. Gambe in pressofusione di alluminio verniciate per esterni oppure in alluminio lucidato o satinato per uso interno. Impilabile.  
Mya Tecnica polypropylene seat and mesh textilene back, chair and armchair version. Die-casted powder coated aluminium legs suitable for outdoor use or polished and brushed finish for indoor use. Stackable.

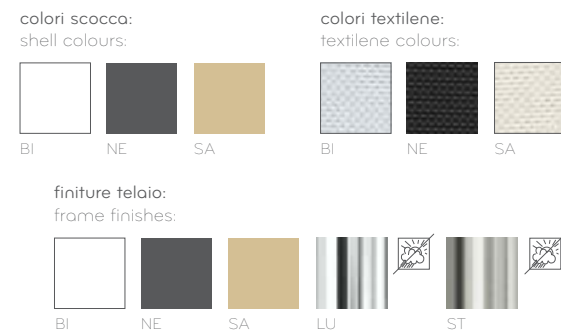
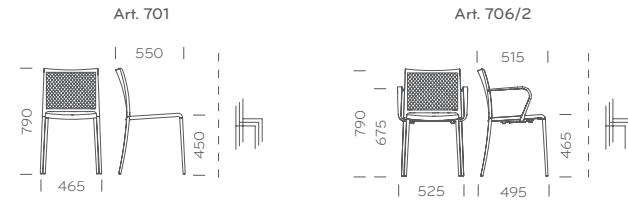

701

Art. TMD\_200X86

Matrix Outdoor ha struttura in alluminio anodizzato e ripiano a doghe in compact full colour bianco, ideale per l'esterno.  
Matrix Outdoor with anodized aluminium legs and leaves in solid laminate white compact full colour. Ideal for outdoor use.

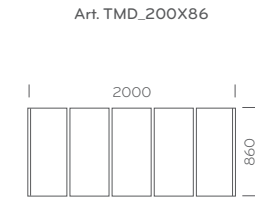

Design Claudio Dondoli and Marco Poggi





Design Claudio Dondoli and Marco Pucci

Art. 870

Joi è una sedia impilabile con seduta e schienale monoscocca in polipropilene. Gambe in estruso d'alluminio anodizzato satinato a sezione quadrata con spigoli arrotondati. Joi può essere dotata di gancio di connessione laterale in nylon per comporre file di sedute in sale riunioni, anfiteatri, aule. Ideale sia indoor che outdoor.

Joi is one piece moulded seat and back polypropylene chair. The legs are made in square satin anodized extruded aluminum with round edges. Joi can be equipped with a connector in nylon to form rows of seats. It's stackable and can be used both indoors and outdoors.

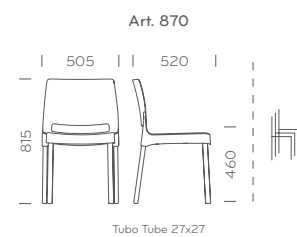

colori scocca:  
shell colours:



BI

NE

MA

VE

RO

finitura telaio:  
frame finish:



ST



# 28 Snow

Design Odo Fioravanti



1° Premio Young&Design 2008

## Art. 300 - 301

La forma pulita, l'adattabilità agli ambienti esterni e interni e l'impilabilità rendono la sedia Snow un nuovo classico. E' realizzata in polipropilene caricato con fibre di vetro e stampata a iniezione mediante l'utilizzo della tecnologia gas air moulding, che la rende solida e al tempo stesso leggera. Snow table vuole comunicare le stesse sensazioni di dinamismo e velocità già proprie della Snow chair. Tavolo con ripiano in polipropilene stampato in gas air moulding e gambe in estruso di alluminio. Ideale per indoor e outdoor.

The clean form, adaptability to indoor and outdoor environments and stackability make the Snow chair a new classic. Made in polypropylene reinforced with glass fibers and injection moulded by the use of air moulding gas technology, the chair is solid and light at the same time. Snow table wants to communicate the same feeling of dynamism and speed of the Snow chair. Table with shelf in polypropylene moulded by air moulding gas and legs in extruded aluminum. Ideal for indoor and outdoor.

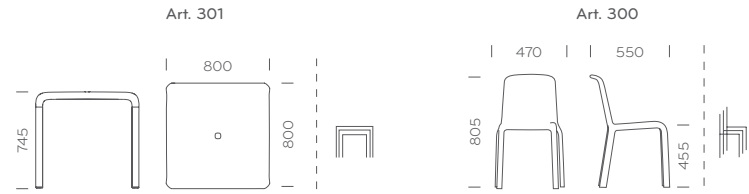

colori art. 300 / art. 300 colours:



colori art. 301 / art. 301 colours:







Design Odo Fioravanti

Art. 303 - 301 JR

L'estetica innovativa e organica, che dal 2008 ha reso Snow una sedia di successo, ha ispirato un adattamento naturale al mondo dei più piccoli senza perdere la forza di una forma ormai inconfondibile. In polipropilene caricato con fibre di vetro e stampato ad iniezione con gas moulding. La versione bassa del tavolo Snow può essere affiancata alla sedia Snow Junior creando piccole aree accoglienza per bambini. Ripiano in polipropilene stampato in gas air moulding e gambe in estruso di alluminio. Ideale per indoor e outdoor.

The innovative and organic design, that has made Snow a successful chair since 2008, has been a perfect inspiration of the world of kids without losing the strength of an unmistakable shape. Made of polypropylene reinforced by glass fibers, injected with moulding technology. The small version of the Snow table can be combined with Snow Junior chair, as an ideal solution for children areas. Table with extruded aluminium legs and gas air moulding polypropylene top. Ideal for indoor and outdoor.

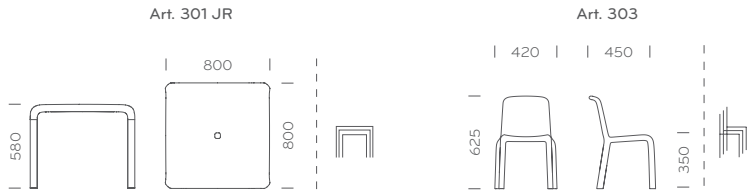

colori art. 303 / art. 303 colours:

BI	AZ	RA	GI	RO

colori art. 301 JR / art. 301 JR colours:

BI	BE



300



303



303



# 32 Matrix

Design Claudio Dondoli and Marco Poggi

## Art. TMA

Tavolo Matrix allungabile con struttura in estruso di alluminio anodizzato o verniciato. Sistema di allunghe telescopiche in estruso d'alluminio che permettono l'estensione di un metro in lunghezza. Le gambe sono munite di ruote che ne facilitano l'apertura. Ripiano in vetro temperato laccato.  
Matrix extensible table with extruded anodized or powder coated aluminium frame. Telescopic sliding rail system allows 1 meter of extension. Wheeling system that allows the legs slide. Tempered laquered glass top.

Art. TMA\_130X86

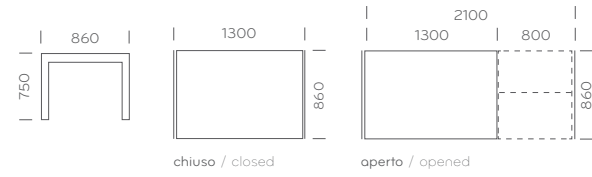

Art. TMA\_165X86

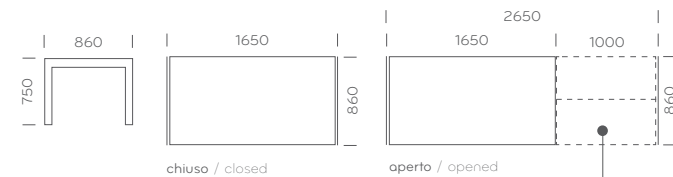

Finitura allunghe: MDF laccato argento  
Folding extension finish: silver laquered MDF

colori vetro / glass colours:



finiture struttura / frame finishes:

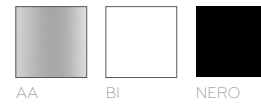

Dettaglio della gamba in alluminio anodizzato.  
Detail of the anodized aluminium leg.



# Enjoy



Design Claudio Dondoli and Marco Pucci

Art. 460

Compatta e leggera, Enjoy è una sedia pieghevole in polipropilene utilizzabile anche negli ambienti outdoor. Facilmente movimentabile, una volta riposta occupa uno spazio di soli 95 mm.  
Compact and lightweight, Enjoy is a polypropylene folding chair suitable for indoor and outdoor use. Once folded, it occupies only 95 mm.

Art. 460

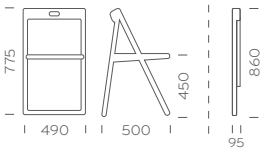

colori / colours:



# 36 Tweet

Design Marc Sadler

## Art. 890 - 895

Tweet nasce dalla volontà di creare un elemento di arredo razionale e adatto ad essere inserito anche negli ambienti più connotati, rispettandone lo stile. La scocca è in polipropilene stampato a bi-iniezione, con finitura retro lucida e parte frontale opaca antigraffio. Il telaio in acciaio Ø14 mm è disponibile verniciato, cromato o cromato nero. Sedia e poltrona sono impilabili.

Tweet was conceived from the desire of creating a rational piece of furniture suitable to be placed even in the most characteristic spaces, respecting their style. Bi-injected moulding polypropylene shell and steel tube frame Ø14 mm. Glossy finish on the back of the shell, matt and scratch resistant on the frontal shell. Frame in chromed, black chromed or powder coated. Chair and armchair are stackable.

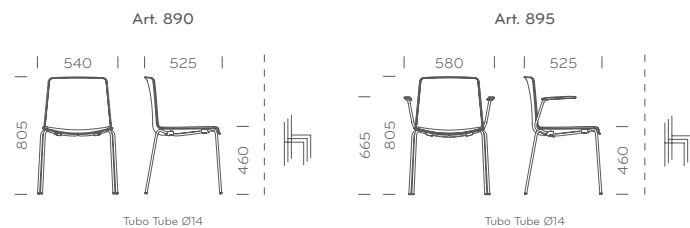

## colori scocca / shell colours:



## finiture telaio / frame finishes:



890



Design Marc Sadler

## Art. 897 - 898

Tweet nasce dalla volontà di creare un elemento di arredo razionale e adatto ad essere inserito anche negli ambienti più connotati, rispettandone lo stile. La scocca è in polipropilene stampato a bi-iniezione, con finitura retro lucida e parte frontale opaca antigraffio. Il telaio a slitta in tondino Ø11 mm, verniciato o cromato. Sedia e poltrona sono impilabili.

Tweet chair was conceived from the desire of creating a rational piece of furniture suitable to be placed even in the most characteristic spaces, respecting their style. Bi-injected moulding polypropylene shell with sled frame in steel rod Ø11 mm, chromed or powder coated. Glossy finish on the back of the shell, matt and scratch resistant on the frontal shell. Chair and armchair are stackable.

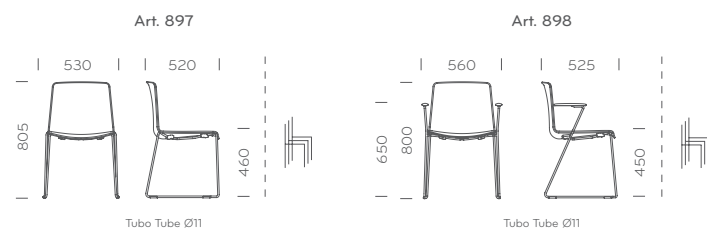

## colori scocca / shell colours:



## finiture telaio / frame finishes:



897



898

# Noa

Design Marc Sadler



reddot design award  
winner 2013

Art. 725 - 726 - 727 - 728

Noa unisce l'eleganza delle sue perfette proporzioni al comfort della seduta, il tutto grazie all'innovativa tecnica costruttiva. La seduta è imbottita ed è contenuta in una scocca in policarbonato la cui superficie esterna è lucida. Telaio in tubo d'acciaio cromato o verniciato. Sedia e poltrona Noa sono disponibili anche nella versione con base a 4 razze in pressofusione di alluminio verniciato, su ruote. Noa combines the elegance of its perfect proportions to the comfort of the seat, all thanks to the innovative construction technique. The seat is upholstered and contained in a polycarbonate shell with a glossy outer surface. Chromed or powder coated steel tube frame. Chair and armchair with 4 feet die-casted aluminium base on wheels also available, white and black powder coated finish.

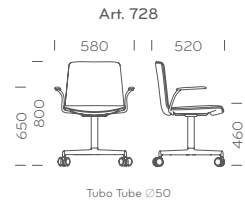
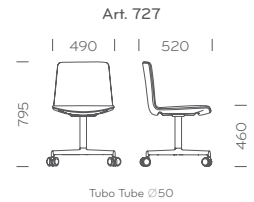
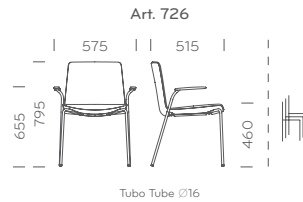
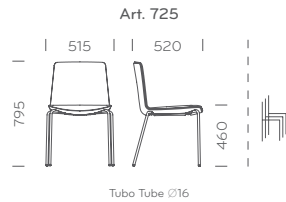

Categorie rivestimenti disponibili: G, H  
Covering categories available: G, H

colori scocca:  
shell colours:

BI	NE

finiture telaio:  
frame finishes:

BI	NERO



728



# 42 L002

Design Alberto Basaglia Natalia Rota Nodari

## Art. L002S - L002T - L002ST

Due gusci in policarbonato stampato si uniscono per creare la lampada L002. Il guscio interno, in materiale opalino, diffonde la luce e allo stesso tempo nasconde la lampadina, quello esterno permette di avere diverse tonalità di colore. La base e lo stelo delle versioni da terra sono in acciaio verniciato bianco o nero in finitura opaca. Two injected polycarbonate shells are joined to create L002. The inner shell is in opal material, diffuses the light and hides the bulb at the same time, the external shell allows the use of different shades of colours. White or black powder coated steel base and frame in matt finish for floor versions.

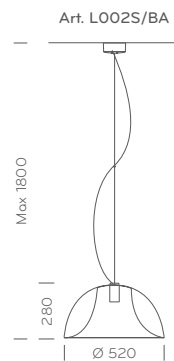

MAX 1X75W E27 220-240V  
CE IP 20

Il dispositivo è compatibile con lampadine di classi energetiche: da E ad A++  
The device is compatible with bulbs of the following energy classes: from E to A++

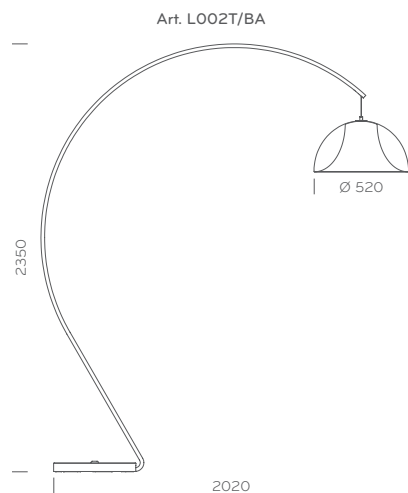

FBT 1X100W E27 220-240V  
CE IP 20

Il dispositivo è compatibile con lampadine di classi energetiche: da E ad A++  
The device is compatible with bulbs of the following energy classes: from E to A++

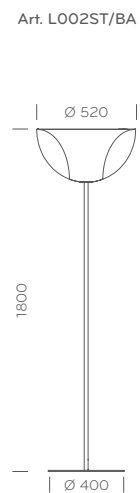

FBT 1X23W E27 220-240V  
CE IP 20

Il dispositivo è venduto con una lampadina di classe energetica: A  
The device is provided with bulb of energy class: A

colori diffusore:  
diffuser colours:



finitura struttura:  
frame finish:



# 44 Matrix Desk

Design Claudio Dondoli and Marco Poggi

Art. TMS

Matrix scrivania a due o quattro postazioni. Ripiani in laminato con apertura per passaggio dei cavi, struttura in estruso d'alluminio anodizzato. Accessoriabile con canalino passacavi e pannello divisorio rivestito in tessuto per la definizione e la separazione dello spazio.  
Matrix two or four seats work station. Laminated tops with wiring gap between one top and the other, extruded aluminium frame, anodized finish. On request, cable management and dividing panel covered in fabric for the definition and separation of the space.

Art. TMS\_200X160

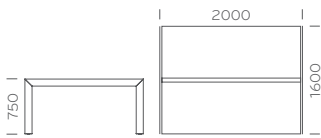

Art. TMS\_350X160

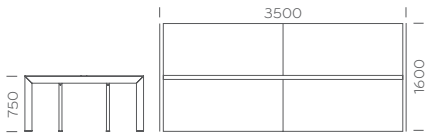

accessori / fittings:

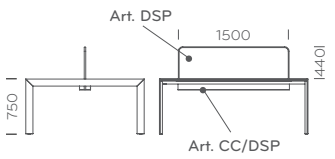

accessori / fittings:

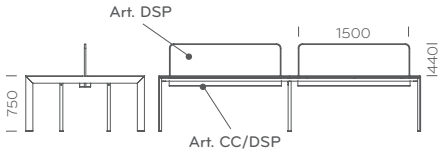

Categorie rivestimenti disponibili: C74+C79  
Covering categories available: C74+C79

finitura struttura:  
frame finish:



AA

colore ripiano:  
top colour:



406\_0020 312



Ripiano in laminato wengè. Gambe in alluminio anodizzato.  
Laminated top in wenge. Anodized aluminium legs.





# 46 Togo



Design Pedrali R&D

## Art. TG

Forme squadrate ed essenziali per il tavolo Togo. Le gambe in estruso di alluminio verniciato sono fissate al ripiano in stratificato mediante piastre in pressofusione di alluminio. Ideale per outdoor.  
Essential and squared off shapes for Togo table. The extruded powder coated aluminium legs are fixed to solid laminate top by 4 cast-aluminium plates. Suitable for outdoor use.

Art. TG\_79X79

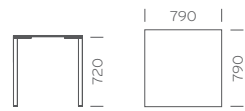

Art. TG\_119X79

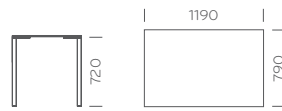

Art. TG\_139X89



finitura struttura:  
frame finish:



BIE

colore ripiano:  
top colour:



CFC.BI



# 48 Laja

Design Alessandro Busano

Art. 880 - 881 - 885 - 886 - 887

La famiglia Laja è composta da sedia e poltrona con 4 gambe in pressofusione di alluminio, poltrona con base centrale a 4 razze in pressofusione di alluminio con e senza ruote, poltrona con telaio a slitta in tondino d'acciaio. Diversi modelli per diversi contesti di utilizzo.  
 Laja family consists of chair and armchair with 4 die-casted aluminium legs, armchair with 4 feet die-casted aluminium base with or without castors, armchair with sled steel rod frame. Different versions for different environments.

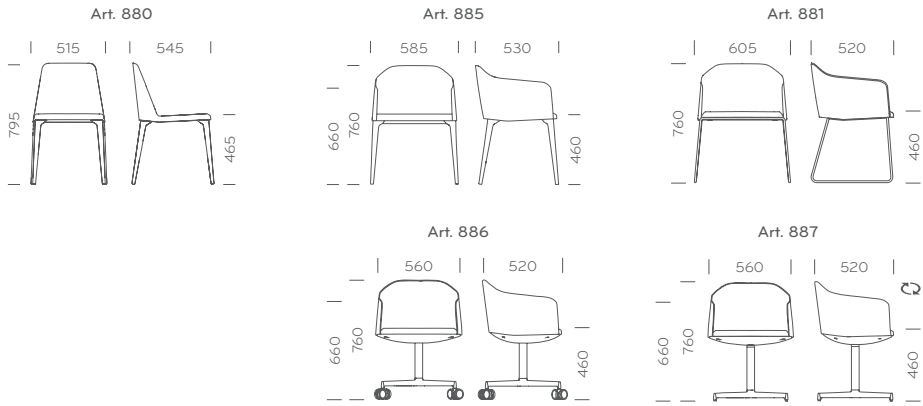

Categorie rivestimenti disponibili: H, G, H+G  
 Covering categories available: H, G, H+G

finiture telaio / frame finishes:



886



# 50 Laja Wings

Design Alessandro Busano

### Art. 889G - 889F

Laja Wings è disegnata per gli ambienti ufficio e casa. I dettagli sartoriali dell'imbottitura sono impreziositi da combinazioni di pelle e tessuto. La struttura in acciaio è immersa in schiuma di poliuretano espanso. Il comfort è garantito dalle cinghie elastiche presenti nella seduta. Nella parte anteriore dei fianchi sono inserite due piccole ruote che agevolano la movimentazione lineare della poltrona. La versione con ruote piroettanti permette una completa mobilità.

Laja Wings is designed for exclusive home and office contexts. The sartorial upholstery details are enriched by a mix of leather and fabric. The comfortable seat is made of crossed elastic belts, covered by polyurethane foam. Two small wheels are inserted in the front part of the sides, enable the linear motion of the chair. The swiveling wheels version offers complete mobility.

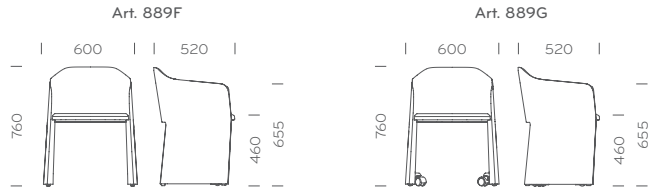

Categorie rivestimenti disponibili: H, G, H+G  
Covering categories available: H, G, H+G



889F



# 52 Arki-Table

Design Pedrali R&D

**Art. ARK**

Lineare e rigoroso nel progetto, versatile nell'adattamento alle diverse situazioni. Il tavolo Arki-Table ha un ripiano ultrasottile in stratificato, le gambe a cavalletto in acciaio e un supporto in estruso di alluminio. Adatto sia per le sale meeting che per le sale da pranzo è disponibile nelle versioni full colour bianco o nero. A richiesta la versione del ripiano con la canalina per i cavi.

Clean and rigorous in the design project but versatile in its different applications. Arki-Table, solid laminate top, frame made of extruded aluminium, trestle steel legs. Arki-Table is suitable either for meeting areas or for restaurant halls. White or black full colour version available. Top available with cable management on request.

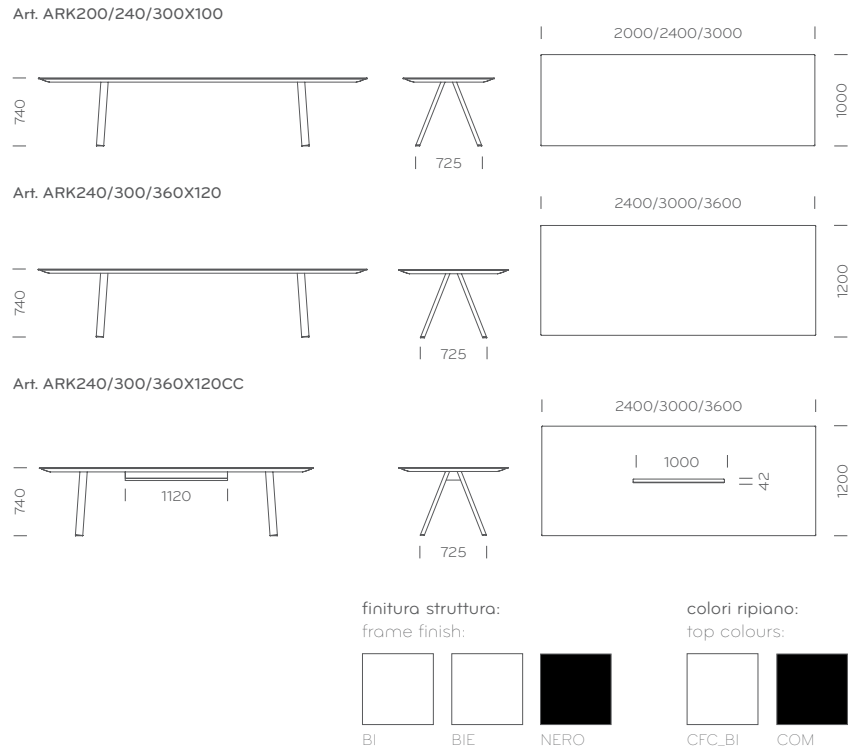

# Koi-Booki



Design Claudio Dondoli and Marco Pucci

### Art. 370

Koi-Booki è una sedia in polipropilene 100% riciclabile, stampata a iniezione, con gambe in estruso di alluminio e telaio in pressofusione di alluminio. Impilabile in verticale fino a 20 pezzi è leggera e resistente. Koi-Booki può essere dotata di gancio di connessione in alluminio anodizzato per comporre file di sedute. Disponibile il cuscino accessorio in tessuto termoformato.

Koi-Booki polypropylene chair, 100% recyclable, injected polypropylene shell, legs of extruded aluminium and frame made of die-casted aluminium. Vertically stackable up to 20 pcs, lightweight and resistant. Koi-Booki can be equipped with an anodized aluminium linking device to form rows of seat. Thermoformed fabric cushion is also available.

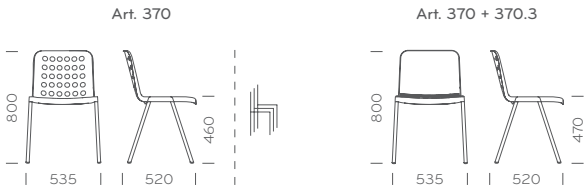

Tubo Tube 22x22

colori scocca / shell colours:



finiture telaio / frame finishes:



# Arki-Table Wood

Design Pedrali R&D

**Art. ARKW**

Look industriale, proporzioni rigorose e versatilità nell'utilizzo. Arki-Table Wood ha le gambe in massello di rovere, il profilo-cornice in estruso di alluminio e il ripiano in stratificato. Disponibile la versione del ripiano con canalino passacavi.

Industrial look, rigorous shapes and versatility. Arki-Table Wood has solid oak legs, extruded aluminium frame and solid laminate top. Top available with cable management.

finituro gambe:  
legs finish:  
RS



colori ripiano:  
top colours:  
CFC\_BI COM

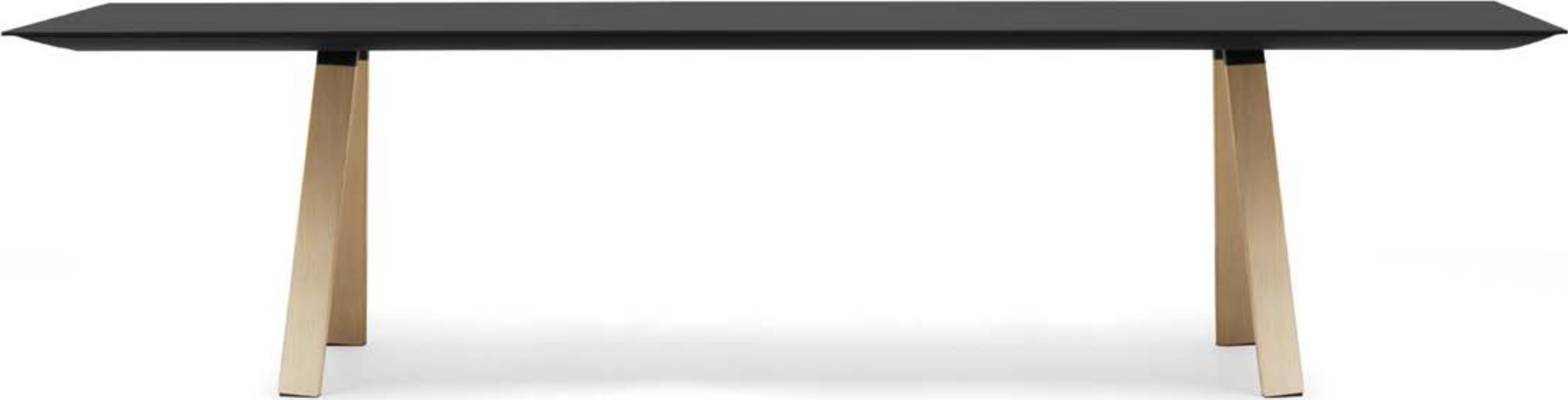
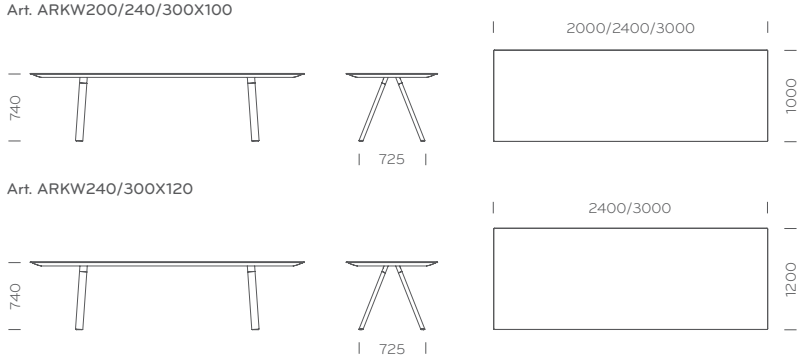

ARKW300X100

## Arki-Table

Design Pedrali R&amp;D

## Art. ARK

Arki-Table nella versione quadrata e tonda mantiene il ripiano ultrasottile e le caratteristiche gambe a cavalletto. Gambe in acciaio verniciato, profilo-cornice in estruso di alluminio e ripiano in stratificato.

Arki-Table square and round version still keep the extremely thin tops and the peculiar structure with trestle legs. Lacquered steel legs, extruded aluminium frame and solid laminate top.

finitura struttura:  
frame finish:



NERO

colore ripiano:  
top colour:



COM

finitura struttura:  
frame finish:



BI

colore ripiano:  
top colour:



CFC\_BI

finitura struttura:  
frame finish:



BIE

colore ripiano:  
top colour:



CFC\_BI

Art. ARK139X139

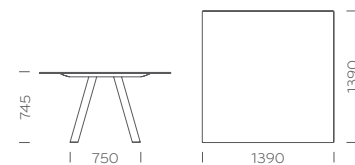

Art. ARKD139

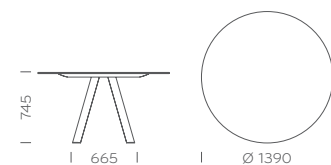

Art. ARKD159

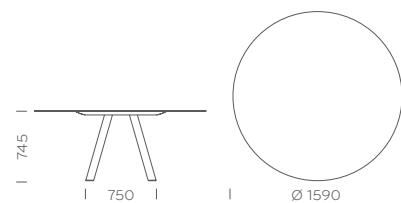

ARK139X139



ARKD159

# Malmö

Allungabile / Fisso  
Extensible / Fixed

Design Michele Cazzaniga, Simone Mandelli, Antonio Pagliarulo

### Art. TML - TMLF

Il tavolo Malmö è nato da un'escursione immaginaria alle rive di un lago in Scandinavia. Di quell'esperienza conserva il tepore di un ritorno al rifugio, il sapore domestico del legno che scalda ogni tipo di ambiente. Allungabile fino a 2900 mm, ha le gambe in frassino abbinato ad un ripiano in stratificato o impiallacciato. Disponibile il tavolo nella versione fisso in 3 dimensioni.

The Malmö table was born from an imaginary journey along the sides of a Scandinavian lake. It recalls the experience of a come back home with the cosiness of wood warming up the environment. Malmö table, extensible up to 2900 mm, ash wooden legs matched with solid laminate or ash veneered table top. Fixed table version in three dimensions also available.

Art. TMLF\_90X90

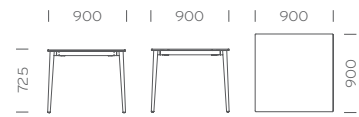

Art. TMLF\_140X90



Art. TMLF\_180X90



Art. TML\_190X90



finiture / finishes:

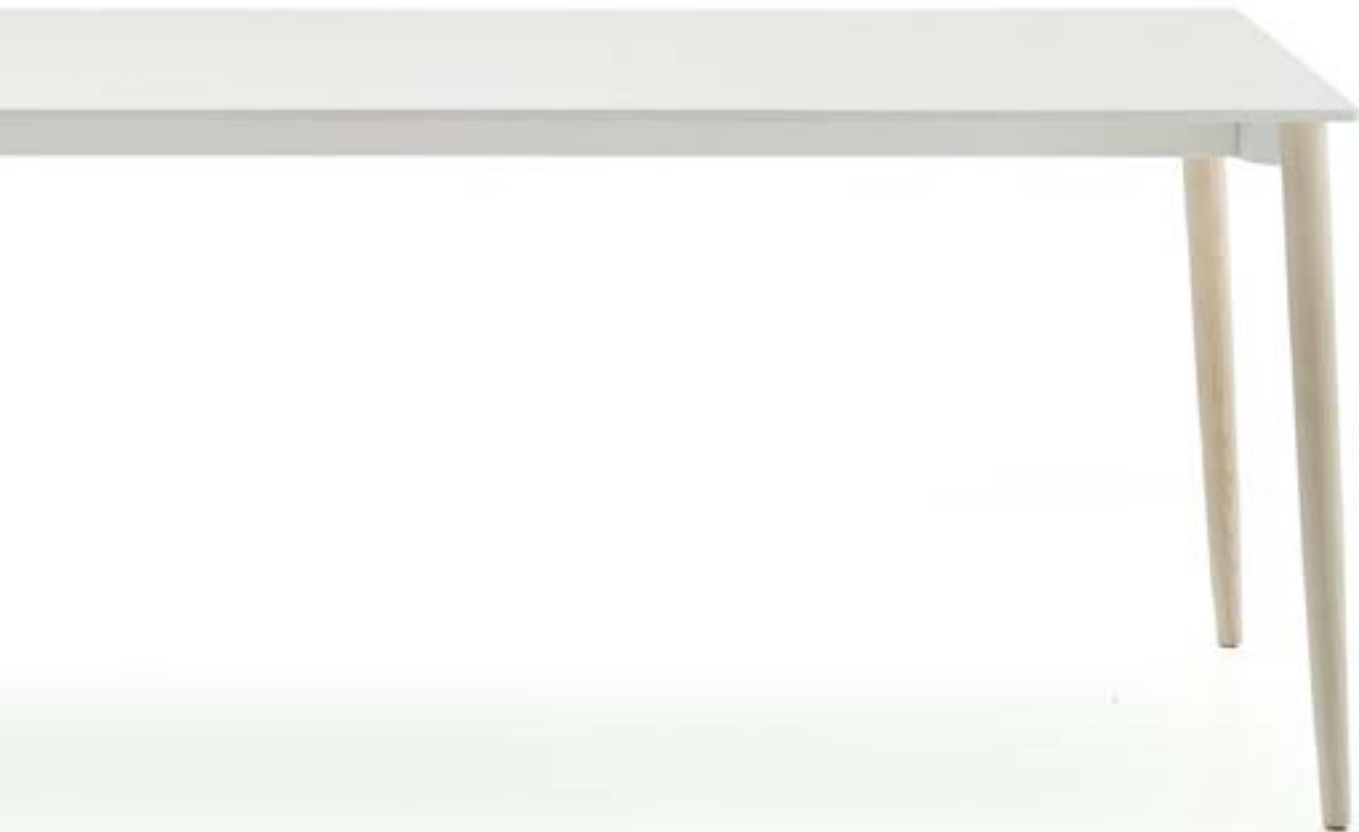
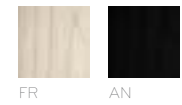

TMLF\_180X90





# 62 Malmö

Art. 390 - 391 - 395 - 232

La struttura in massello di frassino di sedia e poltrona Malmö sostiene una scocca in multistrato curvato, sollevandola ed esaltandone i particolari costruttivi. La sedia impilabile e la poltrona sono state pensate come oggetti accoglienti caratterizzati da linee morbide. Disponibili le versioni imbottite e lo sgabello. Malmö chair and armchair ash timber frame supports a multilayer curved shell, with the aim to raise it enhancing its design particulars. The stackable chair and the armchair had been devised as comfortable items characterised by soft lines. Upholstered versions and barstool also available.

Design Michele Cazzaniga, Simone Mandelli, Antonio Pagliarulo

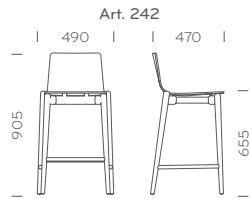
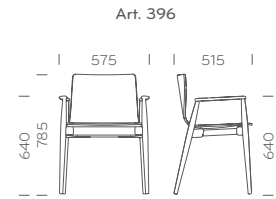
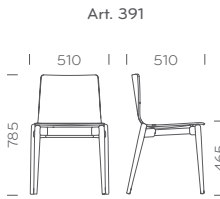
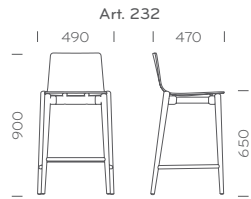
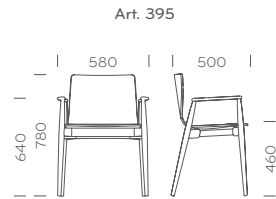
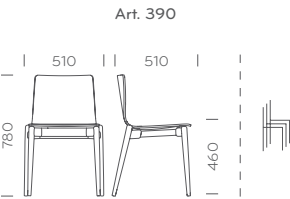

Categorie rivestimenti disponibili: G, H, P  
Covering categories available: G, H, P

finiture / finishes:



390



395



391



232

# 64 Malmö

Tavolini  
Low Tables

## Art. MLT

I coffee tables Malmö hanno il ripiano in frassino impiallacciato, stratificato o mdf laccato e le gambe in massello di frassino tornite. Disponibili in cinque dimensioni.  
Malmö coffee tables with ash veneered top, solid laminate top or lacquered mdf top and tapered legs in ash wood. Five dimensions.

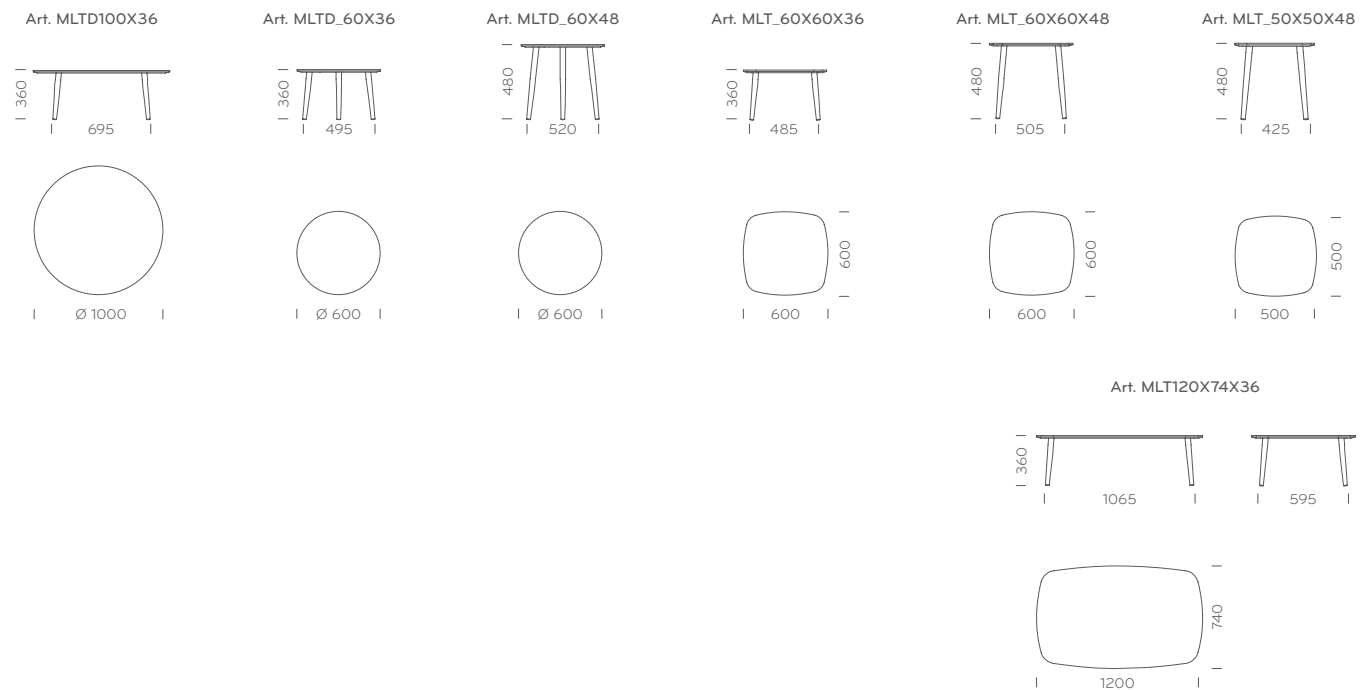

MLT120X74X36

finiture ripiano impiallacciato:  
veneered top finishes:

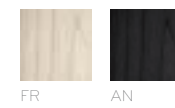

colori ripiano MDF laccato:  
MDF lacquered top colours:



Escluso art. MLT120X74X36  
Excluded item MLT120X74X36

colori ripiano stratificato:  
solid laminate top colours:



Esclusi art. MLT120X74X36, MLTD100X36  
Excluded items MLT120X74X36, MLTD100X36

finiture telaio:  
frame finishes:

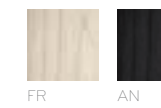

# 66 Tivoli

Design Michele Cazzaniga, Simone Mandelli, Antonio Pagliarulo

## Art. 2800 - 2801 - 2805 - 2806

Tivoli ripercorre il tema delle sedute in legno tradizionali conservando l'idea di comodità e convivialità come misura del gusto. Il profilo essenziale integrato alla perfezione gli elementi strutturali, la curvatura tridimensionale dello schienale ispira accoglienza. Il telaio è in essenza di frassino, il sedile in multistrato e lo schienale in multistrato tridimensionale. Sedile e schienale possono essere imbottiti.

Tivoli recalls the traditional wooden chairs, maintaining comfort and inspiring conviviality. A clean design where the structural elements are perfectly integrated in the frame. The three-dimensional curves and the generous proportions of the back rest make Tivoli an ergonomic and elegant chair. Ash wood frame, plywood seat and three-dimensional plywood back. Upholstered seat and back also available.

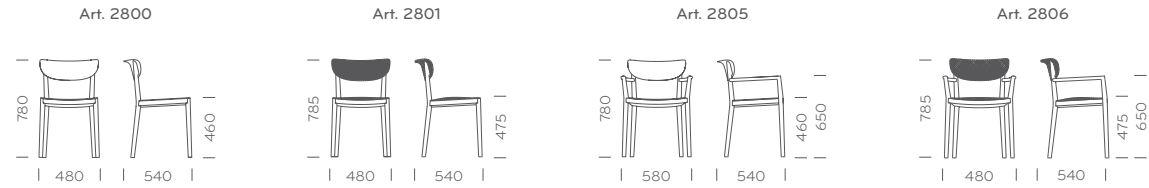

Categorie rivestimenti disponibili: C01-C07, G, H, P  
Covering categories available: C01-C07, G, H, P

finiture / finishes:

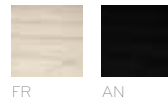

2800



2801



2805



2806

# Frida



Design Odo Fioravanti



German Design Award  
WINNER 2014



### Art. 752

Frida è una sedia che racchiude una tecnologia raffinata e rappresenta un punto di riferimento nella lavorazione del legno. Il fattore più straordinario è rappresentato dalla sovrapposizione di una scocca in multistrato curvato tridimensionale di soli 3,5 mm ad una struttura in legno massello. La struttura in rovere è caratterizzata da sezioni geometriche di forme variabili che si assottigliano lungo i bordi donando un'immagine leggera alla sedia ed esaltando la forza concettuale della scocca.

Frida is a chair that embodies sophisticated technology and represents a landmark in woodworking. The most remarkable factor is represented by the superposition of a three-dimensional curved plywood body of only 3.5mm to a solid wood frame. The oak structure is characterized by geometric sections of varying shapes that taper at the edges, giving a light image to the chair and enhancing the conceptual strength of the body. Available in several finishes.

### Art. 752

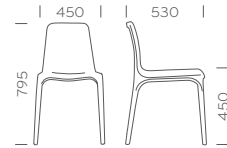

finiture / finishes:



W RS GC BI  
 Rovere laccato  
 bianco poro  
 aperto  
 Open grains  
 white  
 lacquered oak



# Exteso

Design Pedrali R&D

Art. TE\_178X90

Tavolo allungabile Exteso in rovere sbiancato, tinto wengé o faggio laccato bianco goffrato. Ripiano impiallacciato, gambe in massello dalla forma quadrata rastremata verso terra. Le guide telescopiche in alluminio permettono la facile estrazione delle due allunghe.  
Exteso extendable table, oak veneered bleached oak, wenge stained or white matt laquered beech wood. Veneered top, solid square and tapered legs. Aluminium sliding rail guides and two leaves allow to extend easily the table.

finiture struttura / frame finishes:

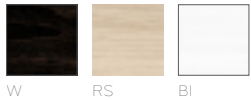

Art. TE\_178X90

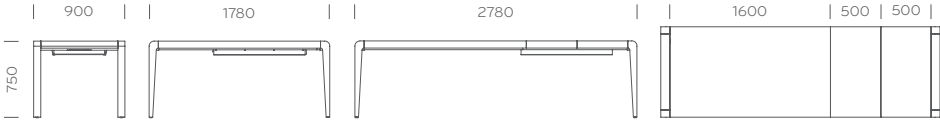

# L001

Art. L001T

Lampada da terra con base e stelo in acciaio verniciato bianco o nero e accensione a pedale. Il diffusore traslucido in policarbonato, singolo o accoppiato, diffonde la luce creando un'atmosfera eterea.  
Floor lamp version with white or black lacquered steel base, large single or double diffuser. Foot pedal to switch on.

Design Alberto Basaglia Natalia Rota Nodari

colori diffusore / diffuser colours:



finitura struttura / frame finish:

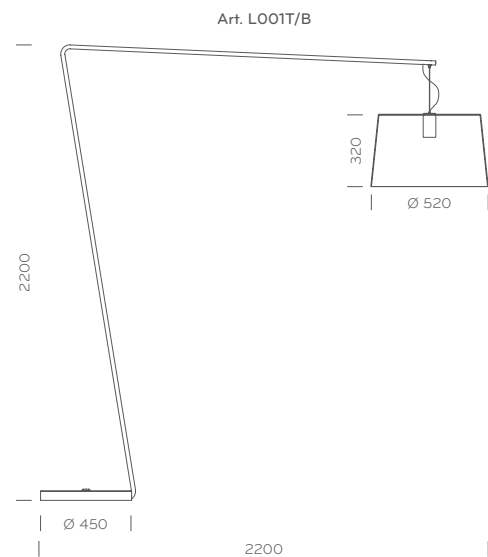

MAX 1x100W E27 220-240V  
CE IP 20

Il dispositivo è compatibile con lampadine di classi energetiche: da E ad A++  
The device is compatible with bulbs of the following energy classes: from E to A++

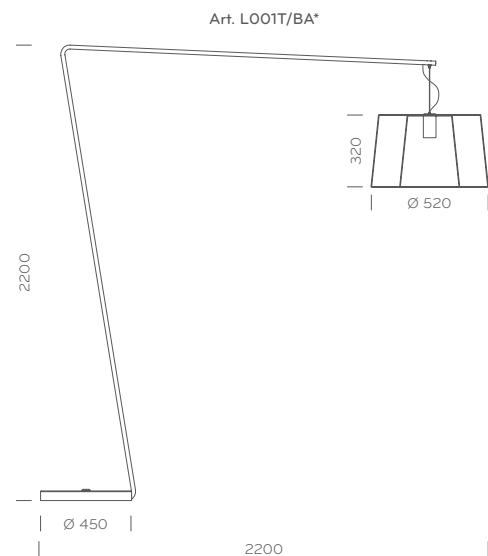

MAX 1x100W E27 220-240V  
CE IP 20

Il dispositivo è compatibile con lampadine di classi energetiche: da E ad A++  
The device is compatible with bulbs of the following energy classes: from E to A++

\* Diffusore interno solo colore BI  
\* Inner diffuser colour BI only



# Sign

Design Daniele Lo Scalzo Moscheri



Art. 455

La poltroncina Sign è realizzata in massello di rovere o noce. Ha una struttura esile ma confortevole grazie alla particolare sezione dei montanti e dei braccioli rastremati che la connotano come lineare ma ricca di dettagli. Seduto imbottito. Armchair Sign is available in solid oak or walnut wood. Its frame is thin but comfortable, thanks to the tapered armrests that featured the armchair with linearity but, at the same time, full of details. Upholstered seat.

Art. 455

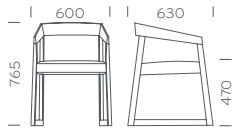

Categorie rivestimenti disponibili: G, H, P  
Covering categories available: G, H, P

finiture / finishes:



# 76 Surface

Design Daniele Lo Scalzo Moscheri

## Art. TSU\_188X90



Tavolo allungabile Surface impiallacciato rovere tinto wengé, impiallacciato noce canaletto o in faggio laccato bianco goffrato. Il terminale e le gambe sono a forte spessore con sezione rastremata, donano quindi leggerezza formale mantenendo le doti di resistenza e stabilità del tavolo. Le guide in alluminio permettono la facile estrazione delle due allunghe.

Surface extendable table oak veneered wenge stained, walnut veneered finish or white lacquered beech wood. Thick and tapered legs give to the table both stability and a touch of lightness. Aluminium sliding rail guides, two leaves allow to extend easily the table.

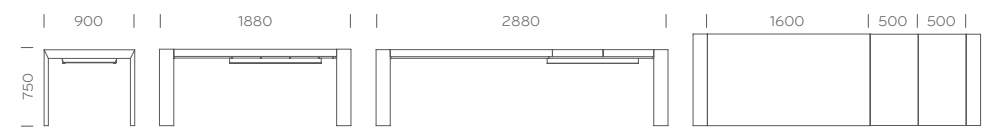
## Art. TSU\_188X90



### finiture / finishes:

		
W	N	Bl
		Faggio laccato bianco goffrato White matt finish lacquered beech





# Log

Design Manuela Buseti, Andrea Garuti, Matteo Redaelli

Art. 365

Log è una sedia completamente imbottita, costituita da un unico volume compatto nel quale è ricavata una comoda seduta che avvolge leggermente il corpo, senza intralciare i movimenti. Grazie all'utilizzo delle migliori tecnologie per gli imbottiti riesce a contenere al massimo il suo peso. La struttura in acciaio è immersa in schiuma di poliuretano espanso.

Log is a fully upholstered one-volume-seating that welcomes the body gently, without hindering movements. Using the best upholstering technologies the weight has been minimized. The steel structure is covered by polyurethane foam.

Art. 365

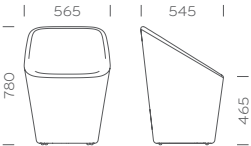

Categorie rivestimenti disponibili: C, G, H20+H35, H80+H90  
 Covering categories available: C, G, H20+H35, H80+H90



Design Patrick Jouin



Art. 690 - 691 - 695

La poltrona Ester è un mix di eleganza, ergonomia e funzionalità. L'attenzione per il dettaglio è onnipresente. Il risultato è un prezioso monolito di pelle, completato dalla raffinata gamba in pressofusione d'alluminio. La seduta è realizzata in schiumato poliuretano con cinghie elastiche su struttura in acciaio, le gambe sono in pressofusione di alluminio. La base centrale a 4 razze munita di ruote rende Ester ideale per gli uffici direzionali e le sale riunioni.

Ester is a mix of elegance, ergonomics and functionality. The attention to details is everywhere. The result is a precious monolith made of leather complemented by refined die-casted aluminum legs. Seat made of polyurethane foam with elastic belts on a steel structure, the legs are die-casted aluminum. The four spokes base with castors makes Ester ideal for executive offices and meeting rooms.

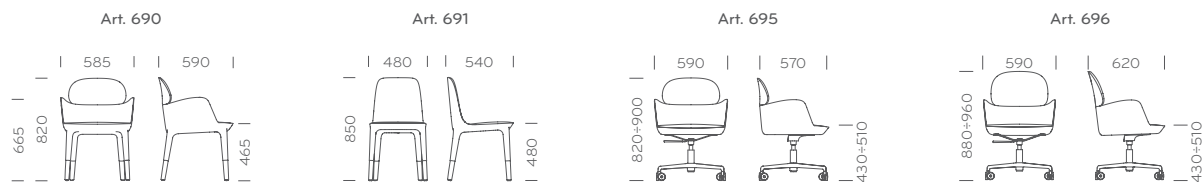

Categorie rivestimenti disponibili: da H20 a H35, P  
Covering categories available: from H20 to H35, P

finiture / finishes:

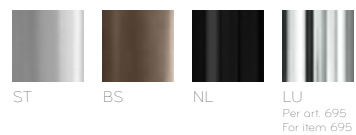

690



691



695



# 82 Magic

Design Pedrali R&D

## Art. TM

Tavolo allungabile con ripiano in vetro temperato spessore 12 mm, trasparente o acidato. Struttura in acciaio inox satinato con gambe a sezione rettangolare 80x40 mm.  
Extensible Magic table with clear or frosted glass top thickness 12 mm. Brushed stainless steel frame 80x40 mm.

### Art. TM\_160X90

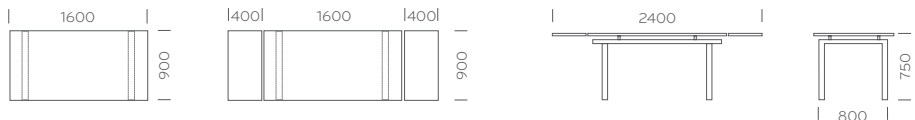

### Art. TM\_200X90

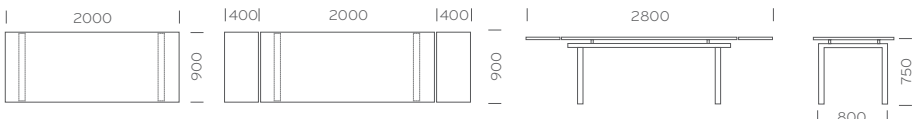

colori vetro:  
glass colours:



finitura telaio:  
frame finish:



# 84 Mood

Design Daniele Lo Scalzo Moscheri

## Art. 720

Mood, elegante poltroncina, avvolgente con forme generose e morbide, realizzata in cuoio naturale. L'attenta cura nei dettagli e nelle finiture la rende importante e raffinata.  
Completely in genuine leather, crafted with great attention to details and finishes, Mood is an embracing and comfortable chair, featured by an elegant style.

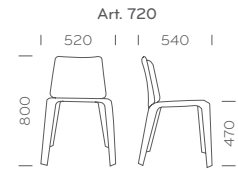

Categorie rivestimenti disponibili: F01, F05, F06, F07, F08, F09  
Covering categories available: F01, F05, F06, F07, F08, F09

## Art. TAE

Tavolo Aero con base in acciaio laccato bianco finitura opaca e ripiano in mdf bianco opaco spessore 30 mm con bordo inclinato. Disponibile anche con base in acciaio laccato nero lucido e ripiano in vetro temperato fumè spessore 12mm con bordo molato.  
Aero table, white lacquered steel base in matt finish, mdf matt white top with chamfered edge 30 mm thickness. Available version with glossy black lacquered steel base, smoke grey tempered glass top thickness 12 mm, chamfered edge.

# Aero 85

Design Daniele Lo Scalzo Moscheri

## Art. TAE\_130X130

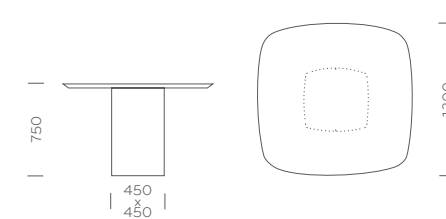

colore ripiano MDF:  
MDF top colour:



BI

finiture telaio:  
frame finishes:



BI

## Art. TAE\_220X106

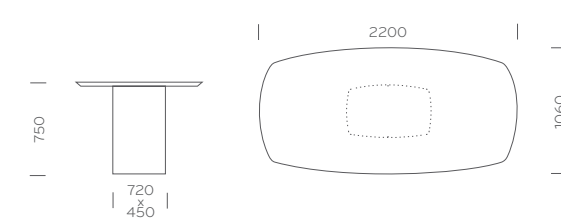

colore ripiano vetro:  
glass top colour:



FU

finiture telaio:  
frame finishes:



NERO



# 86 Allure

Design Pedrali R&D

Art. 735 - 737 - 738

Allure versione sedia è caratterizzata da linee armoniche e morbidi profili. Gambe in massello di rovere, imbottitura in finta pelle. Allure versione poltrona ha angoli raggianti e forme avvolgenti. La morbida imbottitura è racchiusa da un sottile guscio in legno. Struttura in tubo d'acciaio a slitta o su quattro gambe.

Harmonic shapes and soft profiles for Allure chair. Solid oak legs, upholstered seat and back in simil leather. Allure armchair is featured by rounded profiles and embracing shapes. Soft upholstery on wooden shell. Steel tube frame, sled version or four legs version.

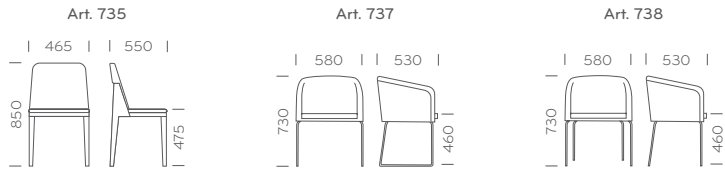

Categorie rivestimenti disponibili: H20, H27  
Covering categories available: H20, H27

**finiture scocca:**  
shell finishes:

W      RS

**finiture telaio:**  
frame finishes:

ST  
Per art. 737, 738  
For item 737, 738



735



738

737

Design Enrico Franzolini

Art. 520 - 521

Sedia e poltrona lounge Jil con struttura in rovere sbiancato, tinto grigio chiaro o tinto tabacco. Il rivestimento della seduta può essere realizzato con un'ampia gamma di tessuti e pelli per offrire grandi possibilità di personalizzazione. L'attenzione dedicata all'ergonomia della seduta garantisce il massimo comfort sia in posizione eretta sia in posizione relax.

Jil chair and lounge armchair with solid oak frame in bleached stained, tobacco colour or light grey stained. The wide range of fabrics, leathers or eco leathers offer great customization possibilities. The attention to the ergonomics of the seat guarantees maximum comfort both in upright position or in relaxed position.

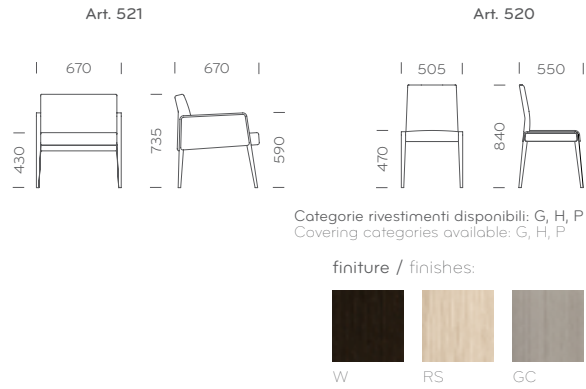

520



# 90 Dress

Design Pedrali R&D

### Art. 530 - 531 - 535

Dress è una famiglia di sedute imbottite che comprende modelli con e senza bracciali, con schienale alto o basso. La struttura e le gambe sono in rovere e i rivestimenti possono essere in tessuto o in pelle in una vasta gamma di tipologie e colori. Sorprendono la snellezza delle gambe, che da sezione quadrata si rastremano verso il basso per diventare tonde, e la leggerezza delle sedute in contrasto con l'eccezionale robustezza che le rende ideali per i luoghi pubblici.

Dress is a family of upholstered chairs that includes armchairs and side chairs, with high or low back. Frame and legs are in oak wood and the upholstery can be fabric, leather or eco leather in a wide range of types and colours. The slenderness of the legs, which are in square section taper down to become round, and the chair lightness surprise while in contrast to the exceptional strength that make them suitable for public areas.

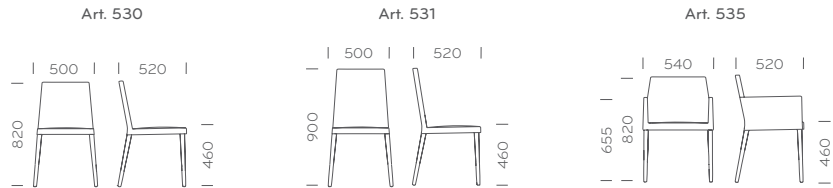

Categorie rivestimenti disponibili: G, H, P  
Covering categories available: G, H, P

finiture telaio:  
frame finishes:

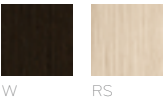

530



535



# 92 Young

Design Pedrali R&D



## Art. 420 - 425

Nata per essere leggera, naturale e al tempo stesso robusta, Young è una sedia ottenuta dall'unione di una scocca in multistrato curvato con una struttura in massello di rovere che ne definisce i contorni e ne esalta la linea sinuosa. Resistente e allo stesso tempo leggera con i suoi 3,5 kg di peso, è disponibile in diverse finiture.

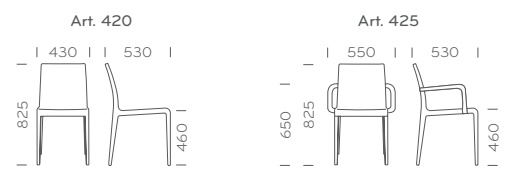
Designed to be light, natural and resistant at the same time, Young is a chair born from the union of a curved plywood body with a solid oak frame, that outlines and enhances its sinuous design. Durable and yet lightweight thanks to its 3,5 kg weight, is available in several finishes.



### finiture / finishes:

				Rovere laccato bianco poro aperto Open grains white lacquered oak
W	RS	GC	BI	
			Per art. 420 For item 420	



420





# 94 Twig

Design Pedrali R&D

**Art. 429**

La sedia Twig, semplice ma elegante, presenta una sofisticata curvatura dello schienale in legno. Disponibile in rovere sbiancato, tinto wengé o tinto grigio chiaro. Schienale in tamburato su ambo i lati, spessore 9 mm. Sedile imbottito.

Twig chair in oak wood. Its thin back profile creates a stylish bending. Both sides of the back are made up with sandwich panels. Solid oak frame available in bleached oak, wenge and light grey stained finish. Provided with an upholstered seat.

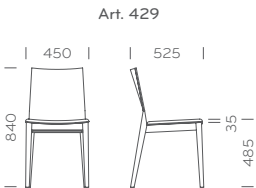

Categorie rivestimenti disponibili: H20, H26, H27, H29  
Covering categories available: H20, H26, H27, H29

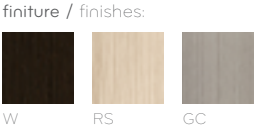

# 96 Zen

Design Pedrali R&D

Art. 429

Sedia Zen con scocca e gambe anteriori in rovere sbiancato o tinto wengé. Le gambe posteriori sono in tubo d'acciaio a sezione 20x20 mm. Grazie alla sua impilabilità è la sedia ideale per il contract.  
Zen chair with shell and front legs in bleached oak or wenge stained. Steel tube 20x20 mm back legs. Thanks to its stackability, the chair is ideal for contract sector.

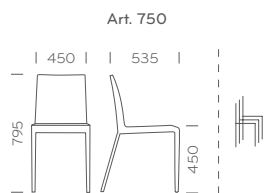

finiture scocca:  
shell finishes:



W

RS

finiture telaio:  
frame finishes:



CR

ST



# 98 L004

Design Alberto Basaglia Natalia Rota Nodari

## Art. L004S

Lampada a sospensione con diffusore in policarbonato verniciato con finitura soft-touch. Il diffusore si sfila senza smontare il corpo elettrico per un facile montaggio e smontaggio.  
Suspension lamp with polycarbonate diffuser soft-touch powder coating. The diffuser can be removed without dismantling the electrical body, for an easy fitting and removal.

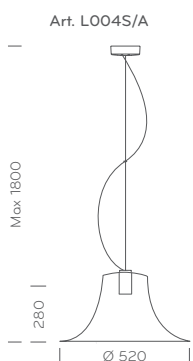

MAX 1x75W E27 220-240V  
CE IP 20

Il dispositivo è compatibile con lampadine di classi energetiche: da E ad A++  
The device is compatible with bulbs of the following energy classes: from E to A++

colori diffusore / diffuser colours:



# 100 Kuadra XL Tecnopolimero

Design Pedrali R&D

Art. 2401 - 2402 - 2403 - 2404

Sedia e poltrona Kuadra XL con scocca in tecnopolimero disponibile in 3 colori. La parte interna dello scocca ha finitura opaca, quella esterna semilucida. Telaio in tubo d'acciaio 20x20 mm o Ø16 mm. Impilabili.  
 Kuadra XL chair and armchair with technopolymer shell in 3 colours. Front part is matt finish, back part is semi-glossy finish. 20x20 mm or Ø16 mm steel tube frame. Stackable.

colori scocca / shell colours:



finiture telaio / frame finishes:



Per art. 2401 - 2402  
 For item 2401 - 2402

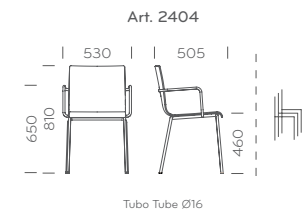
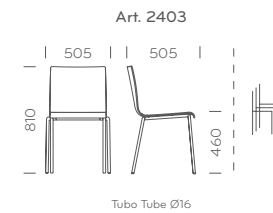
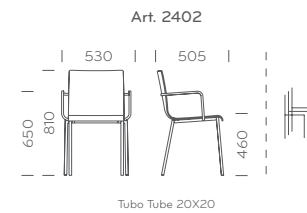
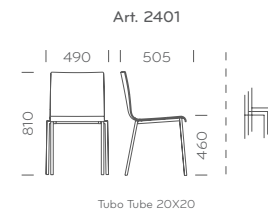

2401



2402



2403



Design Pedrali R&D

Art. 1321 - 1328 - 1331

Sedia impilabile Kuadra con scocca in multistrato impiallacciato rovere spessore 12 mm. Struttura in tubo d'acciaio 20x20 mm o Ø16 mm oppure in tondino d'acciaio Ø10 mm.  
 Kuadra stackable chair with multilayer oak veneered shell, thickness 12 mm. 20x20 mm or Ø16 mm steel tube frame or Ø10 mm steel rod frame.

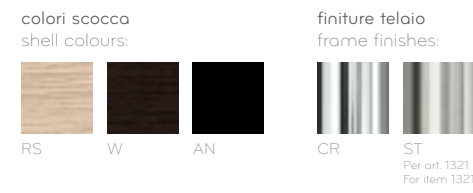
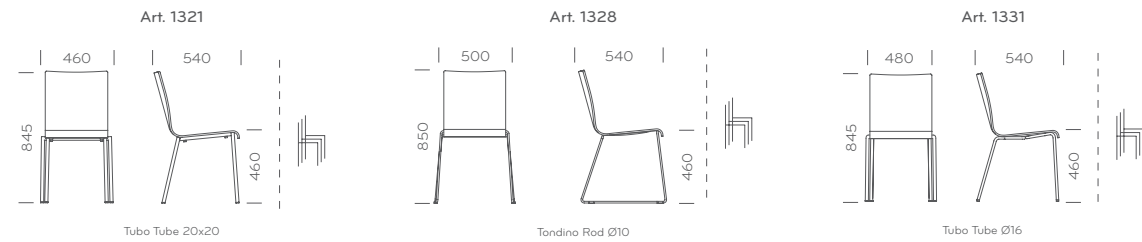

1331



1321



# 104 Kuadra XL

Design Pedrali R&D

Art. 2413 - 2411

Kuadra XL ha linee geometriche ed essenziali. Scocca in multistrato di rovere impiallacciato spessore 12 mm in rovere sbiancato, tinto wengè, tinto nero, acero listellare o noce. Telaio in tubo d'acciaio 20x20 mm o Ø16 mm.  
Kuadra XL has a minimalistic shape. Plywood shell thickness 12 mm, oak veneered in bleached oak, wenge stained, black stained, maple or walnut veneered. 20x20 mm or Ø16 mm steel tube frame.

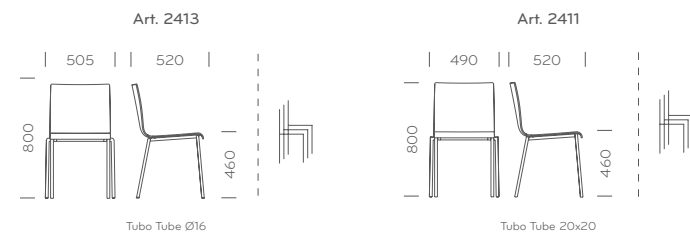

finiture scocca:  
shell finishes:

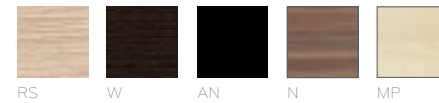

finiture telaio:  
frame finishes:



Per art. 2411  
For item 2411



2413



Design Pedrolì R&D

## Art. TFA

Fabbrico è una collezione di tavoli fissi in diverse dimensioni caratterizzati da un'estetica pulita e linee rigorose. La scelta di utilizzare l'acciaio sia per il ripiano che per le gambe lo rendono riciclabile al 100%. E' disponibile verniciato bianco a polvere per outdoor e verniciato trasparente con effetto industrial per indoor.

Fabbrico is a fixed tables collection of different sizes featured by a clean design and rigorous shapes. The choice of the steel for both the top and the legs makes it 100% recyclable. It is available in different finishes: white powder coated for outdoor use and transparent "industrial" effect for indoor use.

Art. TFA\_70X70

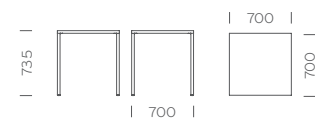

Art. TFA\_80X80

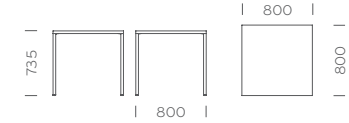

Art. TFA120X80

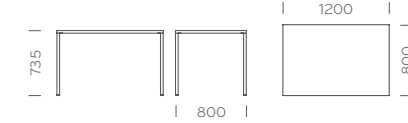

Art. TFA160X80

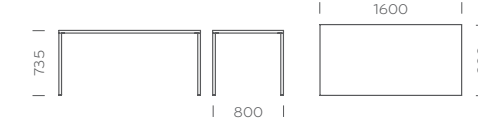

finiture / finishes:

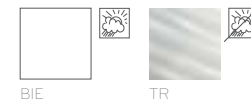

BIE

TR



TFA160X80



TFA\_80X80

# 108 Kuadra Policarbonato

Design Pedrali R&D

Art. 1271

La sedia impilabile Kuadra ha scocca in policarbonato disponibile in diversi colori. La struttura è in tubo d'acciaio 20x20 mm.  
Kuadra stackable chair with polycarbonate shell available in several colours. Steel tube powder coated frame, chrome or satin 20x20 mm.

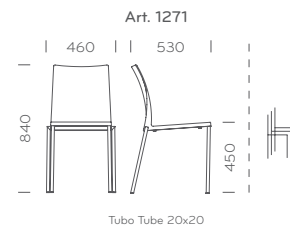

colori scocca / shell colours:



finiture telaio / frame finishes:



Verniciato in tinta con la scocca.  
Powder coated in the same colour of the shell.





# 110 Gliss

Design Claudio Dondoli and Marco Poggi

Art. 920 - 921

La poltroncina Gliss ha scocca in policarbonato disponibile in diversi colori, trasparenti o full colour, oppure in tecnopolimero bianco e sabbia. Telaio a slitta in tondino d'acciaio Ø10 mm.  
Gliss armchair, transparent or full colour polycarbonate shell or white and beige technopolymer shell. Steel rod frame Ø10 mm.

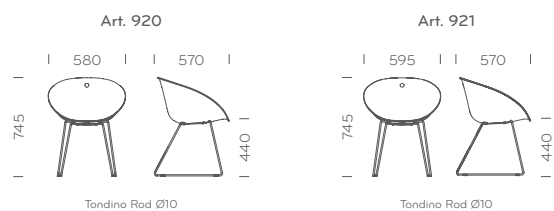

colori scocca:  
shell colours:



BI  
Per art. 920  
For item 920



SA  
Per art. 920  
For item 920



TR



VT



AT



RT



FU



NE

finitura telaio:  
frame finish:



CR



920



# 112 Gliss Tecnopolimero

**Art. 920 - 960 - 900.3**  
 Poltroncina Gliss con scocca in tecnopolimero bianco o sabbia accessoriabile con cuscino sfoderabile in tessuto o pelle. Telaio in tondino d'acciaio cromato Ø10 mm oppure base girevole in pressofusione di alluminio lucidato con ruote e alzato a gas. Gliss armchair, white or beige technopolymer shell, removable cushion in simil leather or fabric covering on request. Chromed steel rod frame Ø10 mm or swivel base on wheels in polished aluminium, gas lift device.

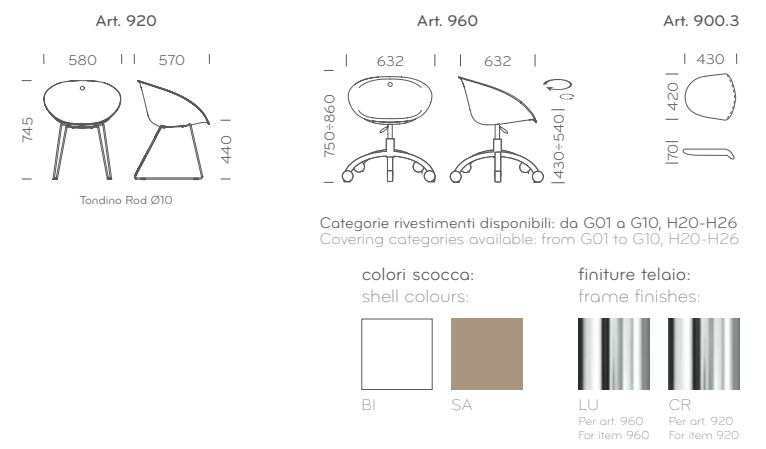

960



# Gliss Lounge Swing

Art. 340 - 341 - 360 - 361 - 340/3 - 350 - 351

La sedia Gliss Lounge è dedicata a chi vuole rilassarsi senza rinunciare alla funzionalità e all'eleganza. Scocca in tecnopolimero oppure rivestita in cuoio naturale, telaio a slitta in tondino d'acciaio oppure base centrale a 4 razze in pressofusione di alluminio.

Gliss Lounge chair is dedicated to those who want to relax without renouncing at functionality and elegance. Technopolymer or genuine leather shell, steel rod frame or 4 feet die-casted aluminium central base.

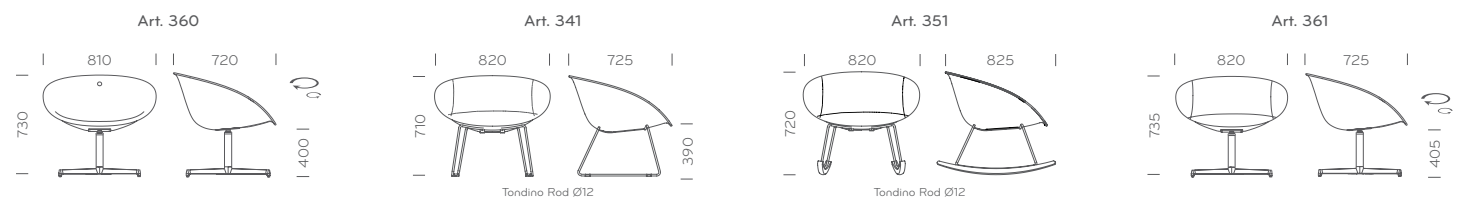

Gliss Swing è la versione a dondolo con telaio in tondino d'acciaio su cui sono montati i due pattini in essenza di frassino. Scocca in tecnopolimero accessoriabile con imbottitura sfoderabile oppure rivestito in cuoio naturale.

Gliss Swing rocking chair with two blocks in ash wood assembled on the steel rod frame. Technopolymer shell upholstered with removable cover or genuine leather shell.





Categorie rivestimenti disponibili: da F01 a F09  
Covering categories available: from F01 to F09

**colori scocca:**  
shell colours:

	
BI	SA

**finiture telaio:**  
frame finishes:

		
BI	CR	FR
Per art. 340, 360 For item 340, 360	Per art. 340, 341 For item 340, 341	Per art. 351 For item 351



360



# 116 Gliss Wood

Art. 904 - 905 - 900.8

Gliss Wood ha gambe in essenza di frassino e scocca in tecnopolimero bianco e avorio oppure in policarbonato trasparente e full colour. Accessoriabile con imbottitura sfoderabile rivestita in tessuto o finto pelle.  
 Gliss Wood chair has ash wooden legs and white and beige technopolymer shell or transparent and full colour polycarbonate shell. Upholstered removable cover in fabric or simil leather on request.

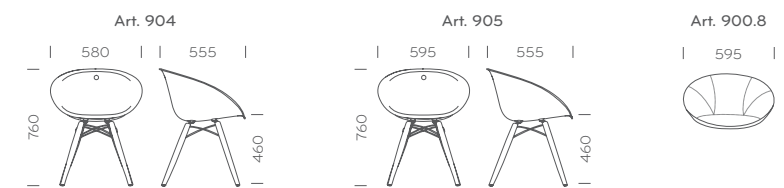

Categorie rivestimenti disponibili: C, G, H  
 Covering categories available: C, G, H

colori scocca:  
 shell colours:

BI Per art. 904 For item 904	SA Per art. 904 For item 904	TR	VT	AT	RT	FU	NE	FR	AN

finiture telaio:  
 frame finishes:



905



904 + 900.8



# 118 Gliss

Design Claudio Dondoli and Marco Poggi

## Art. 930 - 966/F

Sedia Gliss rivestita in cuoio naturale con cuciture a vista in contrasto. Telaio in tondino d'acciaio cromato Ø10 mm. Gliss è disponibile anche con base a cinque razze in alluminio lucidato con ruote adatte per pavimenti in legno. Girevole, con alzata a gas.

Gliss chair, technopolymer shell covered in genuine leather with visible stitches. Chromed steel rod frame Ø10 mm. Polished aluminium base with castors suitable for wood floor also available. Swivel, gas lift device.

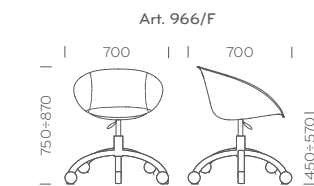
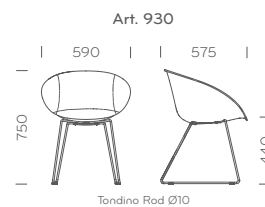

Categorie rivestimenti disponibili: F01+F09  
Covering categories available: F01+F09

finiture telaio:  
frame finishes:



CR	NERO
Per art. 930	Per art. 966/F
For item 930	For item 966/F



966/F



# 120 Gliss

Design Claudio Dondoli and Marco Pucci

## Art. 902 - 970

Sgabello Gliss con scocca in policarbonato in diversi colori, sia full colour che trasparenti. Telaio in fondino d'acciaio Ø12 mm o versione girevole su struttura a base e colonna centrale con alzata a gas.  
Gliss barstool has a round-shaped polycarbonate shell made in bright colours and a steel rod frame Ø12 mm. Swivel version on central base and column with gas lift device also available.

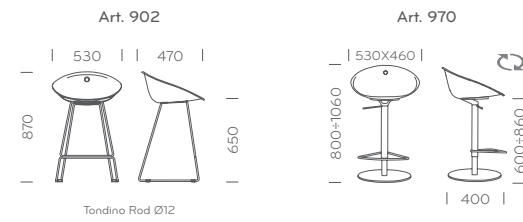

colori scocca / shell colours:



TR

VT

AT

RT

FU

BI

NE

finitura telaio / frame finish:

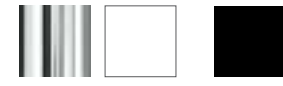

CR

BI

NE

Per art. 902  
For item 902

Per art. 902  
For item 902



970



# 122 Rubik



Design Claudio Dondoli and Marco Pucci

### Art. 580 - 582 - 583

Lo sgabello Rubik è realizzato interamente in policarbonato, materiale atossico con ottime proprietà meccaniche, resistente agli urti, infrangibile. Adatto per esterno. Impilabile, è disponibile in 3 altezze.  
Rubik barstool is fully made of polycarbonate, non toxic material with optimum physical properties, shock resistant, unbreakable. Suitable for outdoor use. Stackable, 3 heights available.

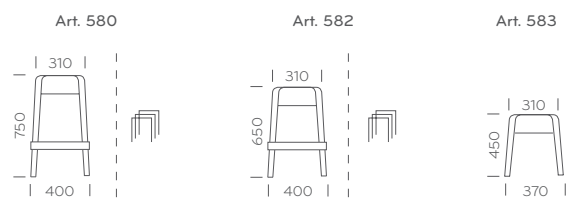

colori / colours:



580



582

583



# 124 Arod

Design Claudio Dondoli and Marco Pucci

## Art. 500 - 570

Sgabello Arod con telaio in tubo d'acciaio cromato o verniciato 15x15 mm e seduta in ABS cromato oppure policarbonato. Disponibile la versione con base centrale in acciaio inox lucidato, colonna e poggiatesta in acciaio cromato. Girevole con alzata a gas regolabile.  
Arod barstool with chromed or powder coated 15x15 mm square steel tube frame and chromed ABS or polycarbonate seat. Swivel version, adjustable in height, with polished stainless steel central base, chromed steel column and footrest also available.

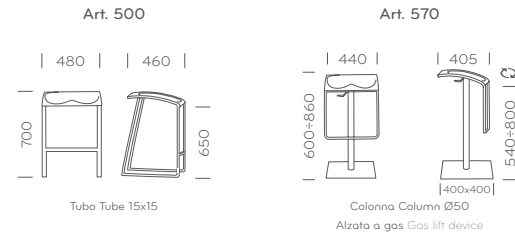

colori scocca:  
shell colours:



SCR TR RT FU RO NE BI

finitura telaio:  
frame finish:



CR BI NE  
Per art. 570 Per art. 500 Per art. 500  
For item 570 For item 500 For item 500

## Art. 1102 - 1112 - 1172

Sgabello impilabile Kuadra con scocca in tecnopolimero bianco o avorio. Struttura in tubo d'acciaio 20x20mm oppure Ø16 mm. Disponibile la versione con scocca in metacrilato e struttura in tubo d'acciaio 20x20 mm.  
Kuadra stackable barstool with white or ivory technopolymer shell. 20x20 mm or Ø16 mm steel tube frame. Methacrylate shell version with 20x20 mm steel tube frame also available.

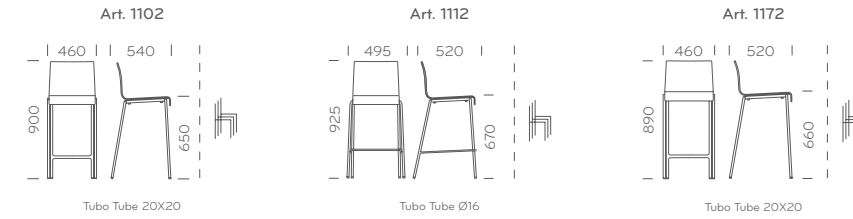

colori tecnopolimero:  
technopolymer colours:

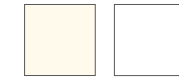

AV BI

colori metacrilato:  
methacrylate colours:



TR GL AL RL

finitura telaio:  
frame finish:



CR ST  
Per art. 1112 Per art. 1102 - 1172  
For item 1112 For item 1102 - 1172

# Kuadra 125

Design Pedrali R&D



570



500



1112



# 126 Woody

Design Odo Fioravanti

Art. 495 - 497

Sgabello Woody con scocca in multistrato impiallacciato rovere o rivestita in cuoio naturale con cuciture perimetrali in contrasto e cuciture trasversali in tinta. Regolabile in altezza.  
Woody barstool, oak veneered plywood shell or genuine leather shell with profile stitches in contrasting colour and matched colour for the cross stitches. Adjustable in height.

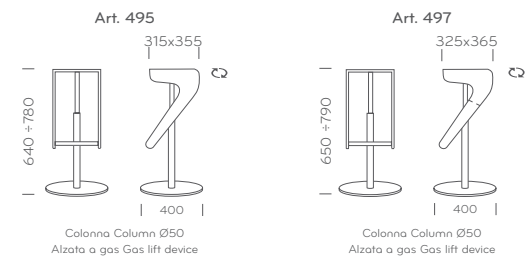

Categorie rivestimenti disponibili: F01, F05, F06, F07  
Covering categories available: F01, F05, F06, F07

finiture scocca:  
shell finishes:



RS W

finiture telaio:  
frame finishes:

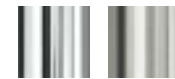

CR ST



497





Art. 380 - 382

Brera sedia e sgabello hanno struttura in legno massello di rovere, sedile e schienale in tamburato. Disponibili nelle finiture rovere sbiancato, tinto wengé o tinto grigio chiaro.  
 Brera chair and barstool with solid oak structure, seat and back in hollow core. Bleached oak, wenge or light grey stained finish.

Design Pedrali R&D

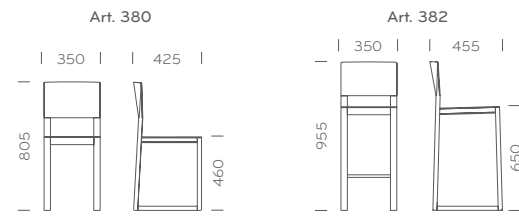

finiture / finishes:

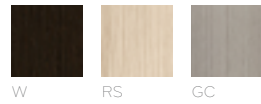

Art. 383 - 387 - 388

Lo sgabello Brera ha forme compatte e linee essenziali. Una seduta versatile che si adatta ai contesti più informali e alle esigenze di spazio ridotte. Realizzato in essenza di rovere.  
 Brera barstool has compact shape and essential lines. A versatile seat ideal for small and informal spaces. Made of solid oak.

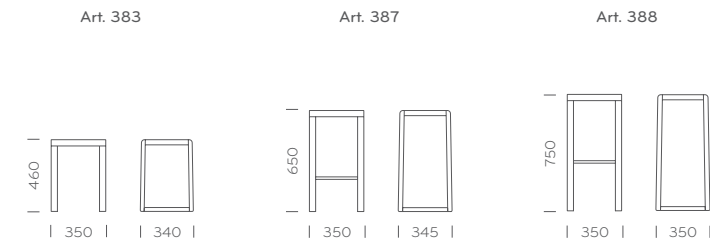

380



382



383



387

# 130 Cube

Design Pedrali R&D

## Art. 1402 - 1403

Sgabello Cube è leggero, confortevole e versatile grazie alle dimensioni ridotte. La soluzione ideale per ambienti che dispongono di piccoli spazi. Telaio in tubo d'acciaio a sezione quadrata 25x25 mm e sedile imbottito.

Cube barstool is lightweight, comfortable and versatile thanks to the small dimensions. The ideal solution for small sized spaces. Square steel tube frame 25x25 mm and upholstered seat.

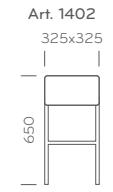

Art. 1402  
325x325  
650  
Tubo Tube 25X25

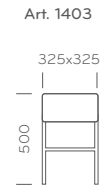

Art. 1403  
325x325  
500  
Tubo Tube 25X25

finiture sedile / seat finishes:



A95 A96

finiture telaio / frame finishes:

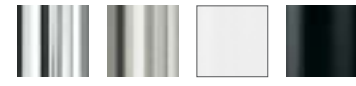

CR ST BI NERO



1402



1403





Design Cristian Gori

## Art. 490 - 491

Happy è uno sgabello alto impilabile che senza base diventa una seduta bassa. Realizzato in polipropilene con l'ausilio del gas per renderlo più leggero, rigido e resistente. Adatto per esterni.  
 Happy is a high and stackable barstool that becomes a lower seat without base. It is made of polypropylene with gas injection system that ensures resistance, lightness and rigidity. Suitable for outdoor use.



1° Premio Young&Design 2007

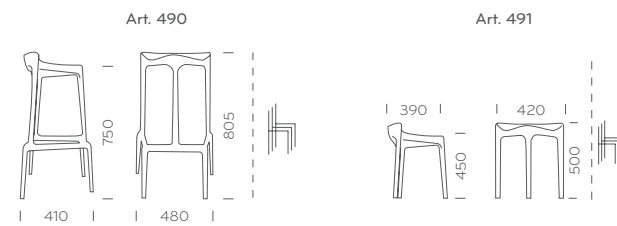

colori / colours:



490



491



# 134 Kuadro

Design Pedrali R&D

Art. TK

Tavolo Kuadro ha struttura in acciaio satinato e ripiano in vetro satinato.  
Kwadro table with satinized steel frame and glass frosted tempered top.

Art. TK\_80X80

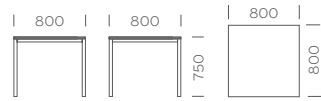

Art. TK\_90X90

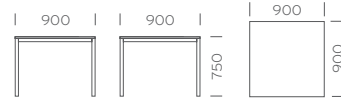

Art. TK\_120X120

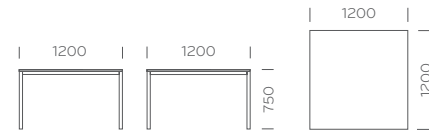

Art. TK\_120X69

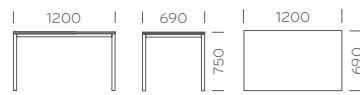

Art. TK\_140X80

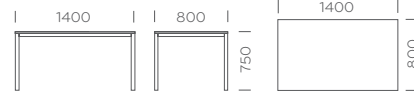

Art. TK\_180X90

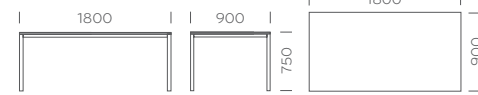

colore ripiano vetro:  
glass top colour:



SAT

finiture struttura:  
frame finishes:



ST



# 136 Day Dream

Design Claudio Dondoli and Marco Poggi



## Art. 401 - 405

Sedia Day Dream con scocca in policarbonato stampato a iniezione. Telaio a slitta in tondino d'acciaio Ø11 mm oppure gambe in tubo d'acciaio Ø16 mm. Il suo design avvolgente la rende ideale sia per gli ambienti contract che residenziali.

An ergonomic shape for Day Dream with polycarbonate injected shell. Ø11 mm steel rod frame or Ø16 mm steel tube legs. The appealing design makes the chair suitable for any environment.

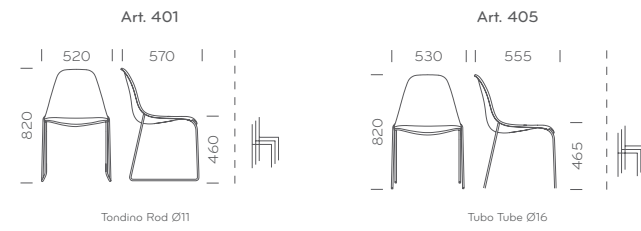

colori scocca / shell colours:



finiture telaio / frame finishes:



405





Design Claudio Dondoli and Marco Poggi

Art. 620

Poltroncina impilabile Gossip in policarbonato. Le forme arrotondate e morbide la rendono una seduta confortevole. Disponibile in diversi colori sia full colour che trasparenti.  
Gossip stackable armchair in moulded injected polycarbonate. The rounded and sinuous shapes offer a high level of comfort. Transparent or full colour version.

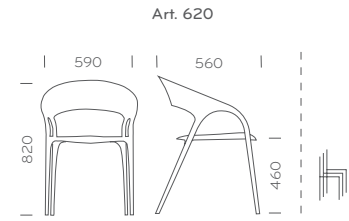

colori / colours:



# 140 Queen



Design Claudio Dondoli and Marco Poggi

## Art. 650 - 650.3

Queen si ispira ai canoni formali tradizionali introducendo elementi di contemporaneità nel disegno, nel materiale e nella tecnologia costruttiva. In policarbonato trasparente o full colour. Impilabile, è accessoriabile con cuscino.  
Queen is fully made of polycarbonate, a strong material suitable for any habitat. The chair is inspired to traditional models but introduce a touch of contemporary design, either for material and construction technology. Queen chair is made of transparent or full colour polycarbonate. Stackable, cushion on request.

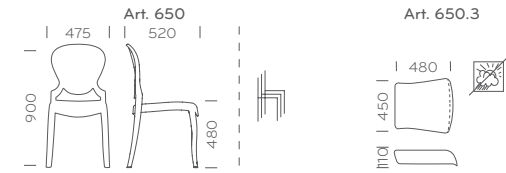

Categorie rivestimenti disponibili: da H40 a H53  
Covering categories available: from H40 to H53

colori / colours:



650 + 650.3





# 142 Pasha

Design Claudio Dondoli and Marco Pucci



## Art. 660 - 660.3 - 661 - 662

La poltrona Pasha è la sintesi tra tradizione e innovazione. Ideale per hotel, ristoranti e ambienti outdoor è realizzata interamente in policarbonato trasparente o full colour. Accessoriabile con cuscino. Il pouf Pasha, tavolino lounge o seduta, è accostabile alla poltrona o proposto come complemento d'arredo indipendente. Accessoriabile con un pratico vassoio realizzato in resina melaminica ad alta resistenza conforme all'uso alimentare.

Pasha armchair is the perfect synthesis of tradition and innovation. It is suitable for hotel, restaurant and outdoor areas as well. In transparent or full colour polycarbonate. Removable cushion on request. Pasha ottoman, lounge table or low seat, can be combined with the armchair or separately used as a fancy complement. Available a practical tray made of high pressure melamine suitable for food use, easy to maintain and to move thanks to the lateral handles.

### colori art. 660-661 art. 660-661 colours:

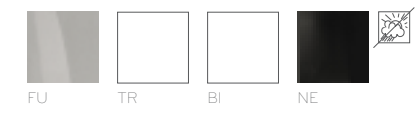

### colori art. 662 art. 662 colours:

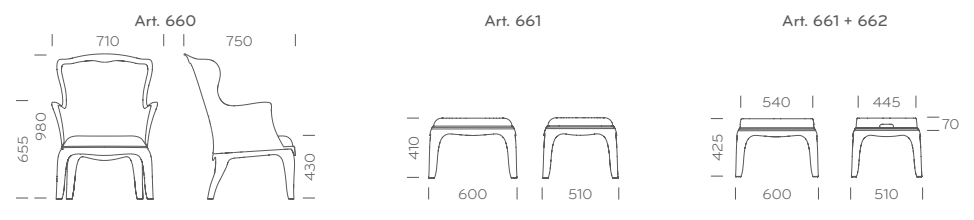
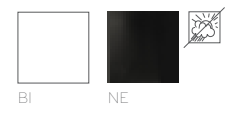

### Art. 660.3

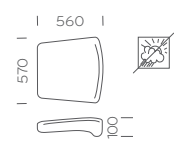

Categorie rivestimenti disponibili: C, G, H  
Covering categories available: C, G, H



661 + 662



# 144 Mies

Design Roberto Semprini

## Art. 415

Dall'eleganza delle linee alla comodità dello seduto. L'idea ispiratrice di Mies è quella di sospendere la morbida seduta rivestita in pelle dal pavimento, cui è collegata da una struttura in metallo satinato dal disegno stilizzato. Ideale come seduta d'attesa.

Soft elegance of design and comfortable seat. The inspiring idea of Mies is to hang the soft sitting in leather up the floor supported by a simple steel frame structure. An appropriate contemporary solution for waiting areas.

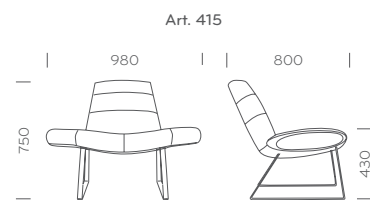

Categorie rivestimenti disponibili: H20, H26, PBI, PNE  
Covering categories available: H20, H26, PBI, PNE

finitura telaio:  
frame finish:



145



# 146 Island

Design Claudio Dondoli and Marco Poggi

Art. 795 - 796 - 797

Semplici nel concetto ma formidabili nell'utilizzo le sedute non convenzionali Island, ideali a completamento di zone relax o per la zona conversazione. Disponibile la versione poltrona e i pouf in due diverse dimensioni. Provisti di fondo antiscivolo.

Island unconventional sittings, an easy concept suitable for relax areas or living rooms. Armchair and pouf version available, 2 sizes. Anti-slipping bottom surface.

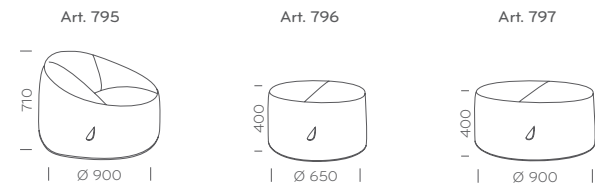

Categorie rivestimenti disponibili: B01, B02, da C90 a C95  
Covering categories available: B01, B02, from C90 to C95



Provisto di maniglia.  
Supplied with handle.



# 148 Host

Design Pedrali R&D

## Art. 200 - 201 - 202 - 203

Sistema modulare di sedute Host. Lineare e rigoroso nella forma può essere posizionato in spazi più o meno compatti per creare aree di attesa o relax a seconda delle esigenze. L'altezza della seduta e la sua profondità lo rendono confortevole anche per un lunch o un aperitivo.  
Host modular seating system. Thanks to its linear and rigorous shape, it can be placed in compact spaces to create waiting rooms or relax areas in order to meet different needs. The height of the seating and its depth make it suitable both for lunch and happy-hour.

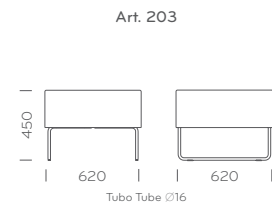
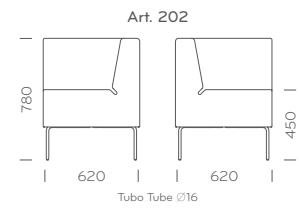
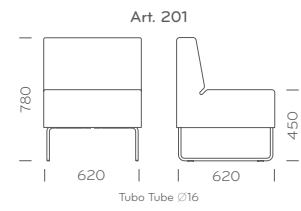
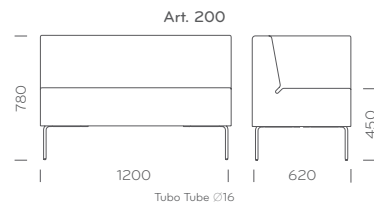

Categorie rivestimenti disponibili: C, G, H  
Covering categories available: C, G, H

finitura telaio:  
frame finish:



CR



201



203



# 150 Zippo

Design Pedrali R&D

Art. ZIP2P/100 - ZIP2P/140 - ZIP1P/100 - ZIP1P/140

Zippo è un divanetto imbottito caratterizzato da linee pulite ed essenziali. Una nicchia di privacy per isolarsi dall'ambiente circostante. L'altezza e la conformazione dei fianchi e dello schienale garantiscono un'ottima capacità fonoassorbente, l'anima della seduta in poliuretano ignifugo a densità variabile e l'inclinazione dello schienale offrono un comfort assoluto. Lungo il perimetro corre una zip che ne delinea le forme, tanto da definirne il nome. Il telaio è in tubo d'acciaio Ø16 mm verniciato in tinta col colore della zip.

Zippo is an upholstered sofa featured by essential and fairly lines. A niche of privacy where being isolated from the surroundings. The height and structure of side and back guarantee a good soundproof capacity. The seat, made of fire retardant polyurethane foam with variable density and the slope backrest offer an extreme comfort. Along the perimeter runs a zip that outlines its forms, so as to define its name. Steel tube frame Ø16 mm is powder coated and matched with the zip colour.

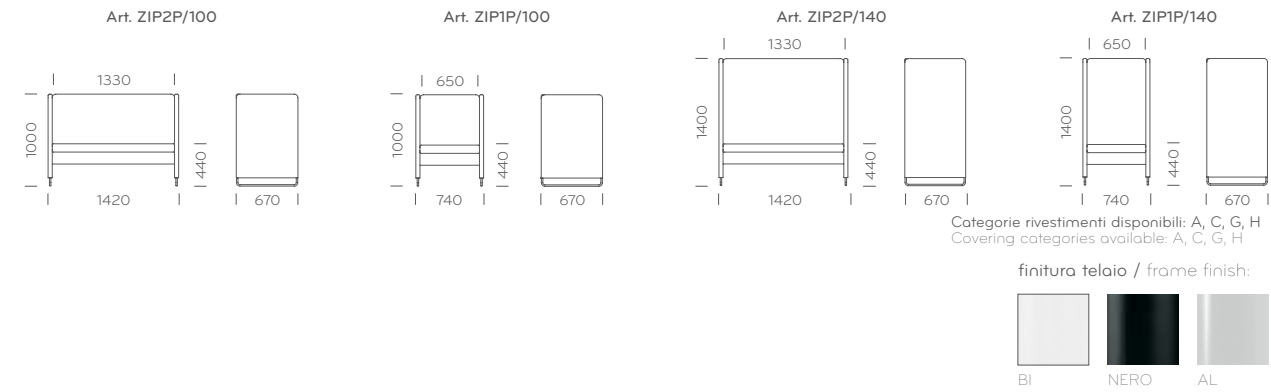

ZIP2P/140



Design Pedrali R&D

Art. 320 - 321 - 322 - 323 - 324 - 325

Wow è un sistema di pouf dalle forme rotonde, quadrate o rettangolari che donano un tocco ironico e casual agli ambienti collettivi e domestici. Disponibili in un'ampia scelta di tessuti e colori, presentano un'imbottitura in schiumato poliuretano ignifugo.

Wow is a system of round, square and rectangular poufs which give a casual and ironic touch to contract and domestic environments. Available in a wide range of fabrics and colors, the upholstery is made of fire-retardant injected polyurethane foam.

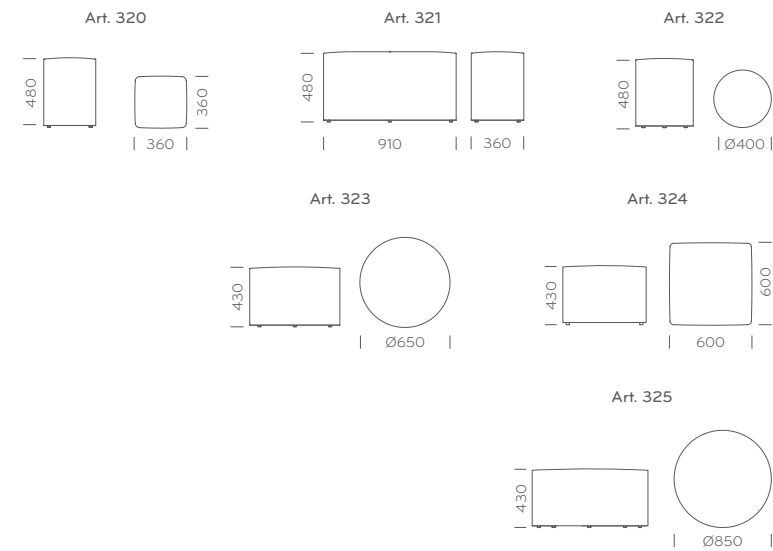

Categorie rivestimenti disponibili: C, G, H  
Covering categories available: C, G, H



# 154 Parenthesis

Design Claudio Dondoli and Marco Poggi

## Art. P10001 - P10002 - P10005 - P10006

Due parentesi tonde che prendono forma per creare elementi geometrici. Contenitore a giorno o comodo piano, coffee table o comodino. Parenthesis è un elemento d'arredo versatile adatto a diversi contesti. I fianchi sono in multistrato di rovere mentre i ripiani in stratificato. Proposto in quattro versioni è disponibile in diverse finiture e combinazioni di colore per dare carattere agli ambienti in cui è inserito.

Two round brackets that create geometric elements. Coffee table or useful top, day container or bedside table. Parenthesis is a versatile furniture object suitable for different contexts. The lateral sides are made of plywood oak and the tops of solid laminate. The four versions of Parenthesis are available in different finishes and colour combinations, so to give character to the environments in which it is inserted.

colore ripiano stratificato:  
solid laminate top colour:



colore ripiano MDF:  
MDF lacquered top colour:



finitura struttura:  
frame finish:

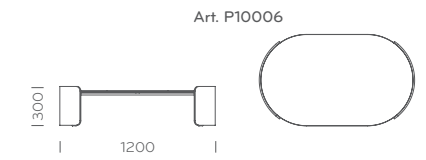
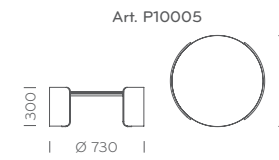
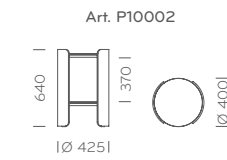
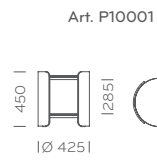
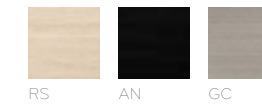

P10001



P10002



P10005

# 156 Set Pocket White

Design Pedrali R&D

## Art. 5800

Set composto da tre tavolini rettangolari impilabili. La struttura è in tubo d'acciaio verniciato bianco Ø16mm e il ripiano in stratificato bianco, spessore 10 mm.  
Three rectangular tables set, stackable. Ø16 mm white powder coated steel tube frame and white solid compact top thickness 10 mm.

### Art. 5800

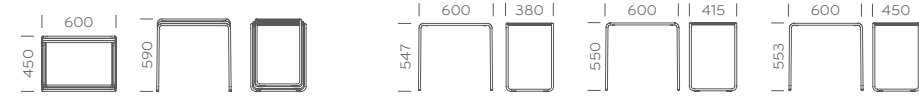

finitura struttura:  
frame finish:



BI

colore ripiano:  
top colour:



CFC\_BI

## Art. 5900

Tavolino con telaio in tubo d'acciaio verniciato bianco Ø16mm e ripiano in metacrilato bianco, spessore 6 mm.  
Low table with Ø16 mm white powder coated steel tube frame and white methacrylate top, thickness 6 mm.

### Art. 5900



finitura struttura:  
frame finish:



BI

colore ripiano:  
top colour:



BI

# Side Table White 157

Design Pedrali R&D



5800



5900



# 158 Code

Design Pedrali R&D

## Art. CODE

Code è una famiglia di tavolini ideali per arredare zone lounge e hall di hotel. Ripiano in stratificato 10 mm, telaio in tubo quadrato 20x20 mm verniciato bianco o nero.  
Code is a collection of coffee tables particularly suitable for lounge areas and hotel halls. 10 mm solid laminate top, 20x20 mm white or black powder coated steel rod frame.

colori ripiano:  
top colours:



Bianco - White



Nero - Black

finiture struttura:  
frame finishes:



BI



NERO

Art. CODE\_40X40X30

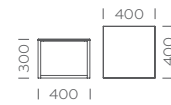

Art. CODE\_50X50X36

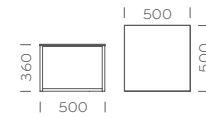

Art. CODE\_59X59X42

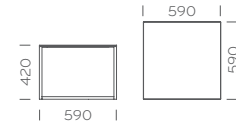

Art. CODE\_40X40X60

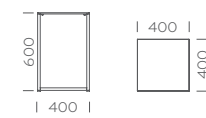

Art. CODE\_119X59X30

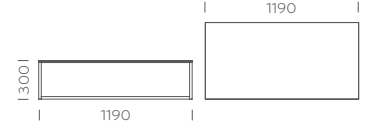

SET\_CODE



CODE\_50X50X36



CODE\_40X40X60

# 160 Flag

Design Pio e Tito Toso

## Art. 5144B - 5145

Flag è un appendiabiti da terra frutto della sintesi fra forma e funzione, l'unione armonica di elementi che lo rendono apparentemente monomaterico. I bracci in polipropilene si raccordano al tubo portante in acciaio e lo completano in modo organico realizzando la funzione richiesta. Flag è un elemento d'arredo versatile che si adatta a tutti i contesti, dal pubblico al domestico, grazie al suo disegno pulito e sobrio e alla possibilità di variare a piacere la posizione dei bracci, assicurando sempre la sua piena funzionalità e la libertà di creare geometrie nuove.

Flag is the perfect synthesis of shape and function. The harmonious combination of different elements makes this coat-hanger mono material looking. The polypropylene arms are inserted into the bearing steel column creating organic lines. Flag is a furniture piece, suitable to all environments, from public to residential. The clean design and the various possibilities to assemble the arms, changing their position to create new geometries, makes it versatile and suitable to different contexts.

Art. 5145



Art. 5144B

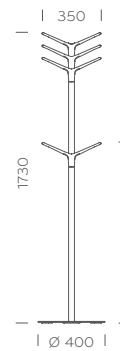

colori / colours:



5144B



Design Pio e Tito Toso



## Art. BRICK - BRICK4

Brick è un portaombrelli caratterizzato da un volume puro che ha il compito di contenere con ordine, occupando il minor spazio possibile. Oggetto pratico per i giorni piovosi, è anche un modulo d'arredo per tutte le altre giornate dell'anno. Realizzato in polietilene stampato rotazionale, ha finitura opaca antigraffio. Due moduli: con 10 fori e 4 fori.  
 Brick is an umbrella stand featured by a pure volume, with the aim of containing in a tidy way and in the smallest possible space. It is a practical object for rainy days as well as a modular piece of furniture for all the other days of the year. Brick is made of rotomoulding polyethylene and it is matt and scratch resistant. Two units available, with 10 holes and 4 holes.

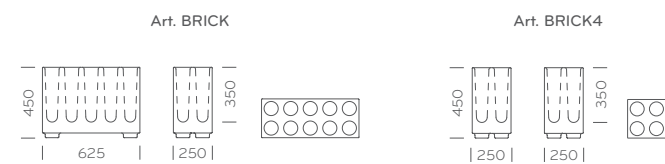

colori / colours:



BRICK4

BRICK



# 164 Kado



Design Pedrali R&D

## Art. KADO

Kado delimita, organizza, arreda e personalizza ogni ambiente del living e del contract. Caratterizzato da linee geometriche ed essenziali, resistente agli urti e agli agenti atmosferici, è atossico e totalmente riciclabile. Disponibile il kit illuminazione e il kit di fissaggio a terra. Kado è realizzato in polietilene con finitura opaca disponibile nei colori grigio antracite, bronzo e bianco.

Kado, ideal solution for delimiting, furnishing and organizing every living and contract location. Featured by essential and simple lines. Shock resistant and waterproof, Kado is non toxic and recyclable. Equipped with lighting kit and floor fixing kit. Kado is made of polyethylene matt finish, available in anthracite grey, bronze and white colours.

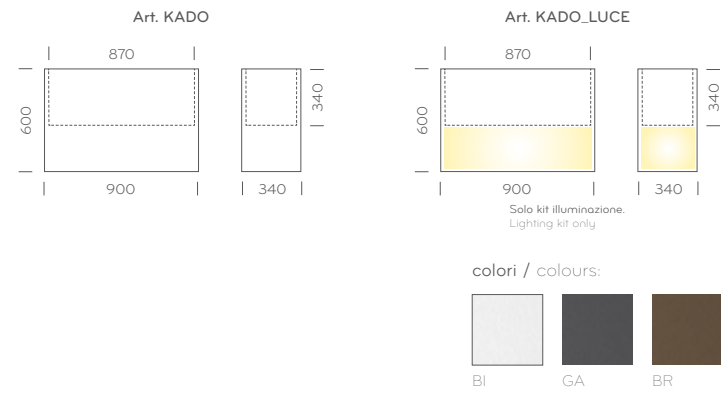

# 166 Colette

Design Alberto Basaglia Natalia Rota Nodari

## Art. LO03TA - LO03TB

Colette è una lampada da comodino o da tavolo che trova la sua essenza nella plasticità delle forme e nel colore. Un cilindro traslucido tenta di imprigionare la luce che si libera pienamente solo in corrispondenza della semisfera che con la sua trasparenza dona leggerezza all'intera lampada. Realizzata interamente in policarbonato in diverse varianti di colore. Colette is a table lamp characterized by the plasticity of the shapes and colours. A translucent cylinder spills completely the light only in correspondence of the half-sphere. Its transparency gives lightness to the whole lamp. It is completely made of polycarbonate and is available in several colours.

Art. LO03TA

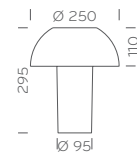

FBT 1X11W E14 220-240V  
CE IP 20

Il dispositivo è venduto con una lampadina di classe energetica: A  
The device is provided with bulb of energy class: A

Art. LO03TB

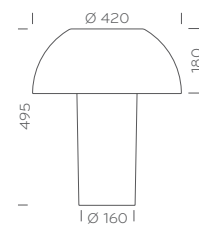

FBT 1X23W E27 220-240V  
CE IP 20

Il dispositivo è venduto con una lampadina di classe energetica: A  
The device is provided with bulb of energy class: A

colori / colours:

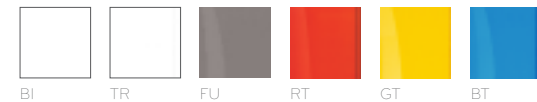

Per art. L003TA  
For item L003TA

Per art. L003TB  
For item L003TB



LO03TA



# 168 Happy Apple indoor

Design Alberto Basaglia Natalia Rota Nodari

Art. 330 - 331 - 332 - 330S - 331S - 330A

Happy Apple versione indoor è una lampada a sospensione, da terra, da muro e soffitto. Una collezione di lampade a basso consumo energetico, in 3 dimensioni, funzionale alle più diverse soluzioni d'arredo.

Happy Apple indoor version, hanging lamp, floor lamp or wall/ceiling lamp. A collection of energy saving lamps in three dimensions, suitable for different furniture solutions.

Art. 330S

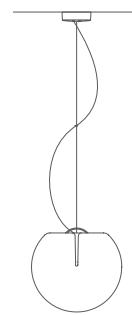

| Ø500 |

FBT 1X15W E27 220-240V  
CE IP 20

Il dispositivo è venduto con una lampadina di classe energetica: A  
The device is provided with bulb of energy class: A

Art. 331S

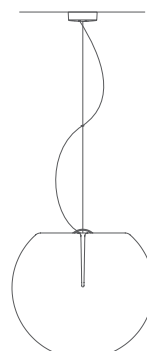

| Ø800 |

FBT 1X23W E27 220-240V  
CE IP 20

Il dispositivo è venduto con una lampadina di classe energetica: A  
The device is provided with bulb of energy class: A

colore rosone:  
fitting colour:



RB

colore cavo:  
cable colour:



TR

colore tappo e maniglia:  
cap and handle colour:



BI

Art. 330



| Ø500 |

FBT 1X15W E27 220-240V  
CE IP 20

Il dispositivo è venduto con una lampadina di classe energetica: A  
The device is provided with bulb of energy class: A

Art. 331

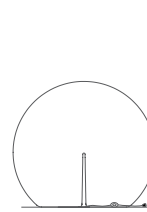

| Ø800 |

FBT 1X23W E27 220-240V  
CE IP 20

Il dispositivo è venduto con una lampadina di classe energetica: A  
The device is provided with bulb of energy class: A

Art. 332

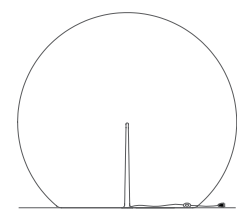

| Ø1200 |

FBT 1X32W E27 220-240V  
CE IP 20

Il dispositivo è venduto con una lampadina di classe energetica: A  
The device is provided with bulb of energy class: A

Art. 330A

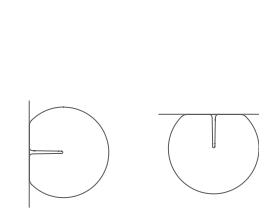

| 440 | | Ø500 |

FBT 1X15W E27 220-240V E27  
CE IP 20

Il dispositivo è venduto con una lampadina di classe energetica: A  
The device is provided with bulb of energy class: A



**CATEGORIA "A"** FINTA PELLE - SIMIL LEATHER



A95 A96

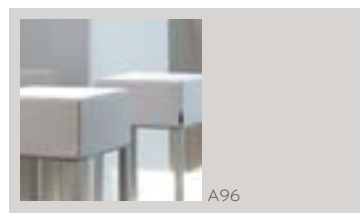

A96

**CATEGORIA "C"** FINTA PELLE IGNIFUGA - FIRE RETARDANT SIMIL LEATHER



C90 C91 C92 C93 C94 C95



C14 C15 C17 C20 C21 C90

**CATEGORIA "H"** FINTA PELLE IGNIFUGA - FIRE RETARDANT SIMIL LEATHER



H20 H26 H27 H29 H34 H35



H34

**CATEGORIA "F"** CUOIO NATURALE - GENUINE LEATHER

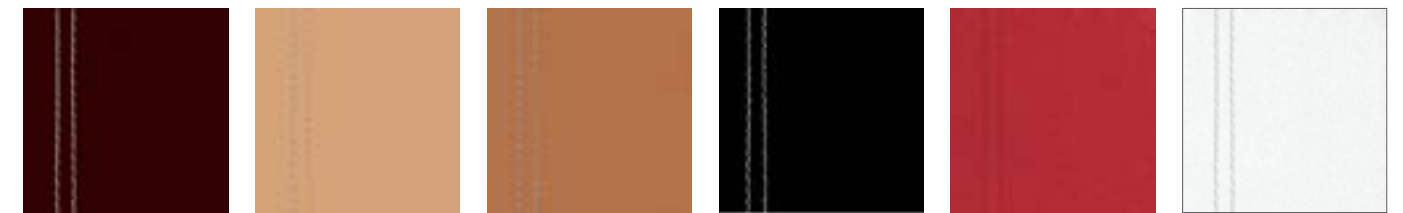

F01 F03 F04 F05 F06 F07



F08 F09

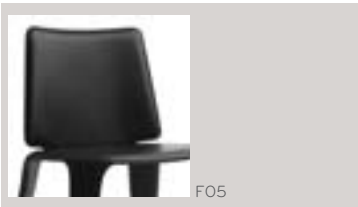

F05

**CATEGORIA "F"** CUOIO RIGENERATO - REGENERATED LEATHER



F11 F12 F13 F17 F18 F19

**CATEGORIA "P"** PELLE MEZZO FIORE - MID GRAIN LEATHER



PBI PSA PGC PGA PGR PBE



PTA PMA PNE PRO

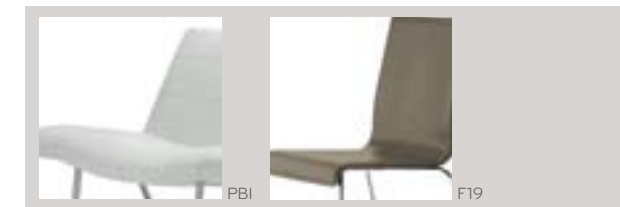

PBI

F19

\* LE CUCITURE SONO IN CONTRASTO PER GLI ARTICOLI: 341, 351, 361, 497, 904/F, 930, 966/F, 1281, 1291, 1298, 2461, 2462, 2463, 2464, 4427/F  
 \* LE CUCITURE SONO IN TINTA PER GLI ARTICOLI: 297, 252, 392, 397, 448, 720  
 \* The stitches are in contrast with the leather colour of items code: 341, 351, 361, 497, 904/F, 930, 966/F, 1281, 1291, 1298, 2461, 2462, 2463, 2464, 4427/F  
 \* The stitches match with the leather colour of items code: 392, 397, 448, 720

**CATEGORIA "H" VELLUTO IGNIFUGO - FIRE RETARDANT VELVET**



H40 H41 H42 H43 H44 H45



H46 H47 H48 H49 H50 H51



H52 H53

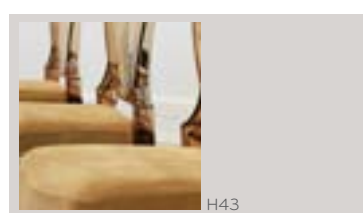

H43

**CATEGORIA "C" LANA IGNIFUGA - FIRE RETARDANT WOOL**



C01 C02 C03 C04 C05 C06

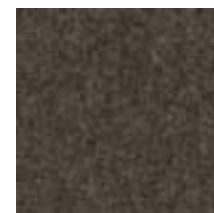

C07

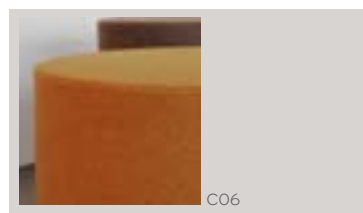

C06

**CATEGORIA "G" LANA IGNIFUGA - FIRE RETARDANT WOOL**



G25 G21 G22 G23 G24



G25

**CATEGORIA "G" TESSUTO IGNIFUGO - FIRE RETARDANT FABRIC**

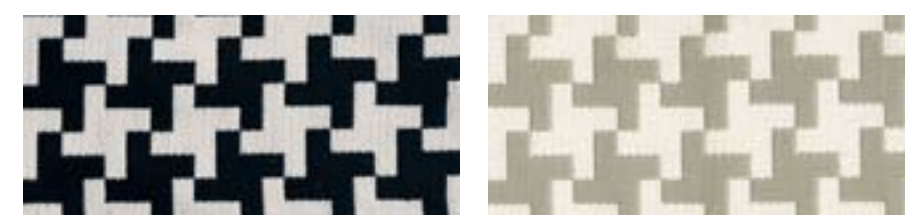

G90 G91



G90

**CATEGORIA "C" TESSUTO IGNIFUGO - FIRE RETARDANT FABRIC**



C70 C71 C72



C70

**CATEGORIA "C" TESSUTO IGNIFUGO - FIRE RETARDANT FABRIC**



C75 C76 C77 C74 C78 C79

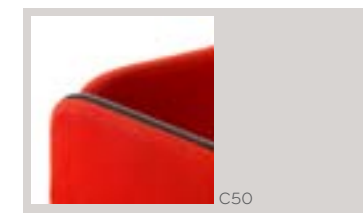

C50



CATEGORIA "D" TESSUTO - FABRIC



D31 D32 D33 D34 D35 D32

CATEGORIA "G" TESSUTO IGNIFUGO - FIRE RETARDANT FABRIC



G59 G60 G61 G62 G63 G64

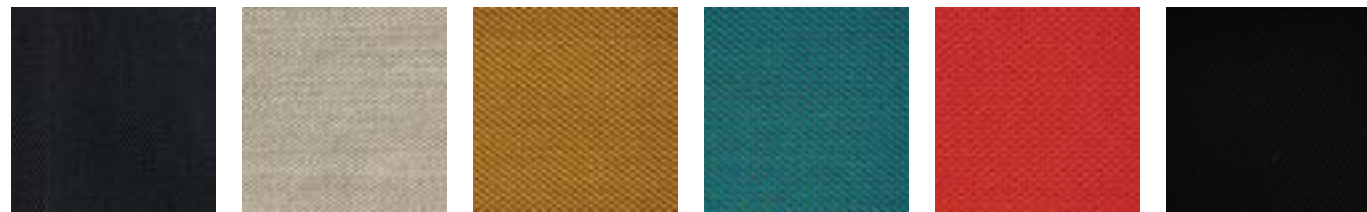

G65 G66 G67 G68 G69 G70

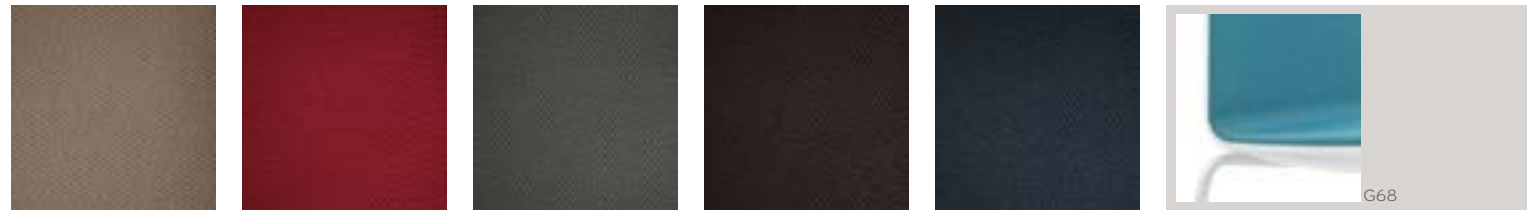

G71 G72 G73 G74 G75 G68

CATEGORIA "H" TESSUTO IGNIFUGO - FIRE RETARDANT FABRIC

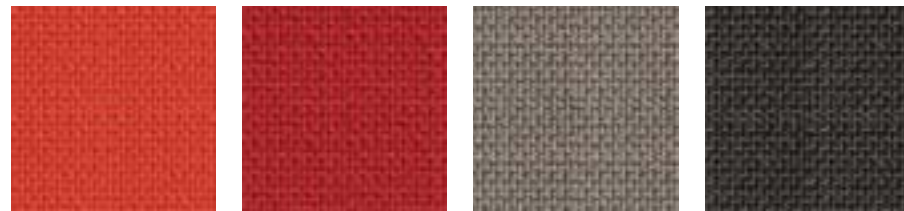

H60 H61 H62 H63



H61

CATEGORIA "G" TESSUTO IGNIFUGO - FIRE RETARDANT FABRIC



G07 G06 G01 G04 G08 G10



G09

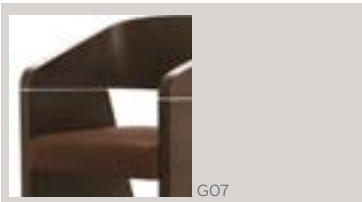

G07

CATEGORIA "B" NYLON - NYLON

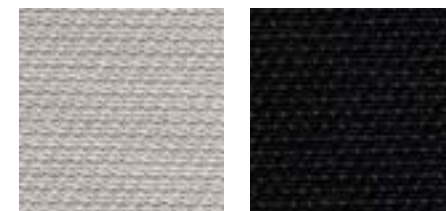

B01 B02

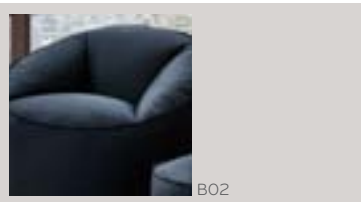

B02

CATEGORIA "C" TESSUTO IGNIFUGO - FIRE RETARDANT FABRIC



C50 C54 C53 C57



C50



The mark of  
responsible forestry

Cerca i prodotti Certificati FSC™  
Look for FSC™ certified products

Pesi, dimensioni e colori sono indicativi. Pedrali si riserva la facoltà di apportare modifiche o migliorie senza alcun preavviso.

Weight, sizes and colours are approximate. pedrali reserves the right to modify or upgrade the product without prior notice.

Tutte le collezioni Pedrali sono protette nel mondo dal diritto di proprietà industriale e da brevetti registrati.

All Pedrali collections are protected throughout the world by industrial design, patent and copyright registries.

Catalogo DesignSolutions | Edizione Ottobre 2014

Photo: Beppe Brancato + Davide Cerati + Ezio Manciuca + Studio Odeon + Ottavio Tomasini

Styling: Cristina Pasini + Silvia Valassina e Barbara Mantovani |

Stampa: Intese Grafiche

Thanks to: LeftLoft

Copyright Pedrali 2014